



# Service Manual

## Compressor Refrigerators

English

**N8DCX**

**N10DCX**

**⚠ DANGER**

Improper installation, adjustment, alteration, service or maintenance can cause personal injury or property damage. Refer to this manual. For assistance or additional information, contact a qualified installer, service agency, or the gas supplier.

**Questions? / Des questions? / ¿Preguntas? 1-800-543-1219**

# CONTENTS

<b>SAFETY</b> .....	<b>2</b>
<b>INTRODUCTION</b> .....	<b>3</b>
About this Manual .....	3
Certification and Code Requirements .....	3
About Installation.....	3
Replacement Parts.....	3
Technical Assistance .....	3
<b>SPECIFICATIONS</b> .....	<b>4</b>
Refrigerator Model Number.....	4
Exploded Views.....	5
<b>GENERAL INFORMATION</b> .....	<b>7</b>
Installation .....	7
Ventilation .....	7
Overview.....	7
12 Volts DC Electrical Connection .....	7
Polarity.....	7
Select Wire Size .....	7
Recommended Wire Size .....	7
<b>DIAGNOSTICS</b> .....	<b>8</b>
Diagnostic Flowchart.....	8
Power Module Self-Test Diagnostics.....	9
Conducting the LED Evaluation.....	9
Prepare to Connect the LED.....	9
Connect the LED .....	9
Diagnostic Charts.....	10
Compressor Power Module Self-Test Diagnostic Chart.....	10
Symptom Diagnostic Chart.....	10
User Interface Control Board Fault Code Chart.....	10
Test A - Compressor Power Module Battery Protection Cut-Out.....	11
Test B - Fan Over Current Cut-Out.....	13
Test C - Compressor Motor Start Error.....	14
Test D - Minimum Compressor Motor Speed .....	15
Test E - Compressor Power Module Thermal Cut-Out .....	16
Test F - Not Cooling, Compressor Not Turning ON.....	17
Test G - Refrigerator Gets Too Cold.....	19
Test H - Refrigerator Builds Frost Inside .....	22
Test I - Compressor Runs But Does Not Cool Properly .....	23
Test J - Will Not Run On DC Power .....	25
Test K - Voltage Within Cut-Out Range But Refrigerator Powers OFF .....	27
Troubleshoot User Interface Control Board Fault Codes .....	29
Fault Code - "E1" .....	29
Fault Code - "E2" .....	31
Fault Code - "E3" .....	33
Fault Code - "E4" .....	34
<b>WIRING DIAGRAM</b> .....	<b>35</b>
<b>REFRIGERATOR ENCLOSURE</b> .....	<b>36</b>
Remove Refrigerator .....	36
Replace Refrigerator .....	36

## FIGURES

Fig. 1 - Refrigerator information label location .....	4
Fig. 2 - Front view .....	5
Fig. 3 - Rear view .....	6
Fig. 4.1 - LED .....	9
Fig. 4.2 - Female connectors .....	9
Fig. 4.3 - 12 VDC .....	9
Fig. 4.4 - Adapter.....	9
Fig. 4.5 - LED .....	10
Fig. 4.6 - 12VDC .....	10
Fig. 5 - Mode button will display User Interface Control Board fault codes.....	29
Fig. 6 - Wiring diagram.....	35

La version française commence à la page 37.

La versión en español comienza en la página 73.

## SAFETY

It is not possible to anticipate all of the conceivable ways or conditions under which the refrigerator may be serviced or to provide cautions as to all of the possible hazards that may result. Standard and accepted safety precautions and equipment should be used when working on electrical circuits and handling toxic or flammable materials. Safety goggles and other required protection should be used during any process that can cause material removal, such as when removing a leaking cooling unit and cleaning components.

Read this manual carefully and understand the contents before working on the refrigerator. Be aware of possible safety hazards when you see the safety alert symbol on the refrigerator and in this manual. A signal word follows the safety alert symbol and identifies the danger of the hazard. Carefully read the descriptions of these signal words to fully know their meanings. They are for your safety.



This signal word means a hazard, which if ignored, can cause small personal injury or much property damage.



This signal word means a hazard, which if ignored, can cause dangerous personal injury, death.



The storage of flammable materials behind or around the refrigerator creates a fire hazard. Do not use the area behind the refrigerator to store anything, especially flammable materials (gasoline, cleaning supplies, etc.).

A circuit overload can result in an electrical fire if the wires and/or fuses are not the correct size. Use only the wire and fuse sizes as written in the "Installation Manual."

Incorrect installation, adjustment, change to, or maintenance of this refrigerator can cause personal injury, property damage, or both. Have service and maintenance work done by your dealer or by an authorized Norcold Service Center.



Disconnect the DC power sources before doing any maintenance work on the refrigerator.

Do not bypass or change the refrigerator's electrical components or features.

Do not spray liquids near electrical outlets, connections, or the refrigerator components. Many liquids are electrically conductive and can cause a shock hazard, electrical shorts, and in some cases fire.

Do not touch the evaporator or other metal parts inside the refrigerator cabinet with wet hands because they can freeze to the refrigerator.

The rear of the refrigerator has sharp edges and corners. To prevent cuts or abrasions when working on the refrigerator, be careful and wear cut resistant gloves.

## INTRODUCTION

### About this Manual

This service manual provides maintenance, diagnostic, and repair information for **NORCOLD**® N8DCX and N10DCX compressor refrigerators. It is a reference tool designed for technicians who are knowledgeable in the theory and operation of AC/DC electrical systems as installed in a variety of recreational vehicles (RV).

All information, illustrations, and specifications contained in this publication are based on the latest product information available at the time of publication. **NORCOLD**® reserves the right to make changes at any time without notice.

### Certification and Code Requirements

- **NORCOLD**® compressor refrigerators are certified under the latest edition of *UL 60335-1* and *UL60335-2-24* standards.
- Electrical components are  compliant.

### About Installation





Refrigerator installation must conform with the N8DCX and N10DCX Series *Installation Manual* for the **NORCOLD**® limited warranty to be in effect. Installation must also comply with applicable local codes and standards set by the relevant certification agency.

### Replacement Parts

Use only authorized **NORCOLD**® replacement parts. Generic parts do not meet **NORCOLD**® specifications for safety, reliability, and performance. The use of unauthorized aftermarket or generic replacement parts voids the refrigerator's limited warranty coverage.

### Technical Assistance

If unable to resolve technical issues using the information provided in this manual, technical support is available through **NORCOLD**® Customer Service Center:

	Telephone:	1-800-444-7210
	Fax:	1-734-769-2332
	email	info@thetford.com
	World Wide Web:	www.norcold.com

The following information is required to process technical support requests:

- Refrigerator Model Number
- Refrigerator Serial Number
- Recreational Vehicle (RV) Make/Model/Year

## Refrigerator Model Number

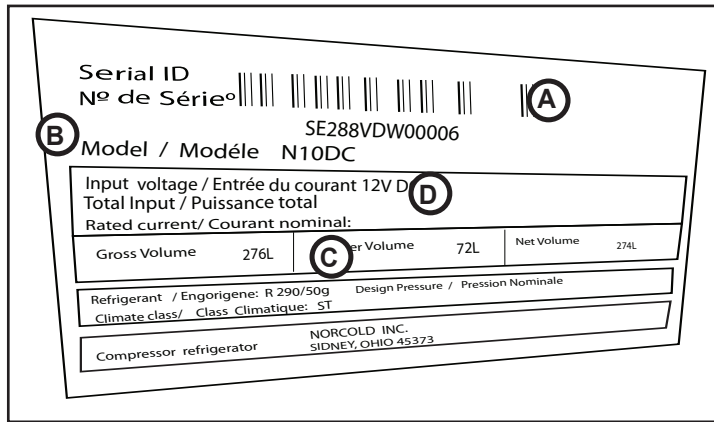

Fig. 1 - Refrigerator information label location

A	Serial Number
B	Model Number
C	Amount of refrigerant in cooling system
D	DC Voltage / Amperage

## SPECIFICATIONS

### N8DCX and N10DCX - Electronic

- ON/OFF, Mode, Temperature Set
- Multiple LED indicator lights
- Five (5) Temperature Settings (Separate settings for freezer and fresh food compartments)
- Night Mode

### Rough Opening Dimensions

- N8DC ----- 52.88 - 53.01 inches high x 23.50 - 23.63 inches wide x 24.00 inches deep
- N10DCX ----- 59.88 - 60.01 inches high x 23.50 - 23.63 inches wide x 24.00 inches deep

### Internal Capacity

- N8DC Total capacity ----- 8.2 cubic feet
- N10DCX Total capacity ----- 9.7 cubic feet

### DC (Direct Current) Specifications

- User Interface Control Board DC Voltage Input Requirement ----- 10.4 to 15.6 ± 0.2 VDC
- Minimum (cut-out) ----- 10.4 VDC
- Restart (cut-in) ----- 11.9 VDC
- Compressor Power Module DC Voltage Requirement ----- 9.6 to 17.0 VDC

### DC Fuse Requirements

- DC Power Supply In-Line Fuse ----- 15 A

### DC Resistance / Amperage Ratings

- Exterior Cooling Fan ----- 0.18A
- Interior Fan ----- .09A
- Interior Light ----- .13A
- Compressor Stall Current ----- 15 A

### NOTICE

The Compressor Stall Current is not measurable with field equipment. The Compressor Power Module monitors this and will self-protect by shutting down after three (3) attempts to start compressor motor.

### Off-level Operating Limits

- Side-to-side ----- 10 degrees maximum at refrigerator
- Front-to-back ----- 10 degrees maximum at refrigerator



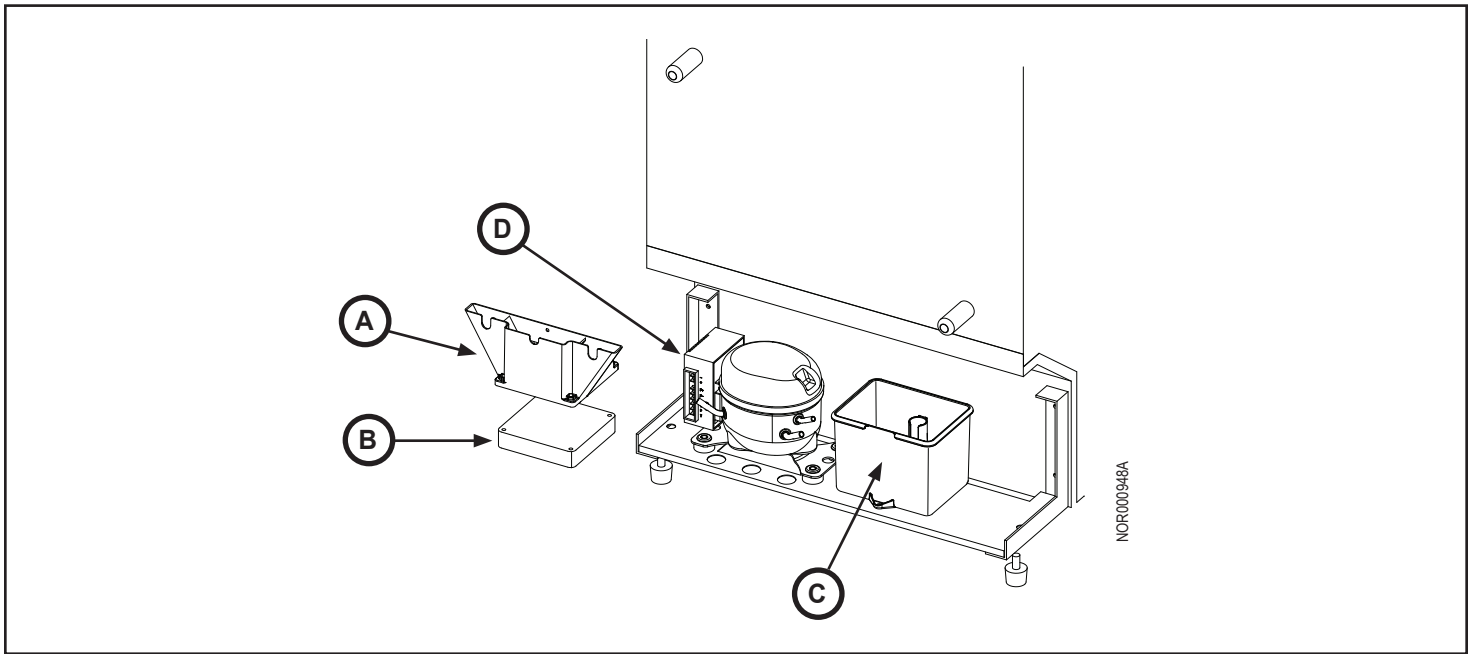

**Fig. 3 - Rear view**

No.	Description
A	Exterior Fan Vent
B	Exterior Fan
C	Drip Cup
D	Compressor Power Module

# GENERAL INFORMATION

## Installation

To confirm that installation is adequate, make sure:

- Ventilation is adequate. Refer to "Ventilation" section.
- Electrical components are installed and operating in a safe condition.
- Refrigerator is installed on a solid and level floor (not on carpet) and secured.
- The floor is able to support the weight of the refrigerator and all of its contents.

## Ventilation

### Overview

The refrigerator is made for a built-in installation. Correct ventilation is necessary for the correct operation of the refrigerator and to increase the life of the refrigerator cooling system.

Ventilation allows the natural flow of air that is necessary for good ventilation. Cooler air comes in through the lower vent, goes around the refrigerator coils where it removes the excess heat from the refrigerator components, and goes out through the upper vent / control cover. If this air flow is blocked or decreased, the refrigerator will not cool correctly. Do not install the refrigerator in a completely enclosed area such as a closet or a cabinet.

### WARNING

The refrigerator has built-in vents at the top and the bottom. Make sure that the air flow through these vents is not blocked in any way. Blockage of the air flow through these vents can:

1. Shorten the life of the refrigerator cooling system.
2. Cause poor cooling performance of the refrigerator.
3. Cause continuous operation of the refrigerator cooling system.
4. Cause fast battery discharge.
5. Void the refrigerator warranty.

## 12 Volts DC Electrical Connection

To reduce the risk of electrical interference from other DC appliances and induction from voltage spikes:

- The refrigerator must have an independent 12 volt supply and not be on the same circuit as other DC appliances.
- Route the DC power supply wires, including the fuses, directly from the battery to the refrigerator.

### CAUTION

The use of a battery in parallel and between the refrigerator and any electrically filtered DC power converter or battery charger used to supply DC power to the refrigerator is recommended.

- Power converters or battery chargers used to supply DC power are examples of installations that should have parallel battery operation.
- If an electrically filtered DC power converter is used as the sole source of power, it must have a maximum DC ripple voltage of less than or equal to 250mV.

### Polarity

### CAUTION

If the DC leads are installed incorrectly, the refrigerator will not operate.

- Connect the DC (positive) supply wire from the battery to the red wire of the refrigerator.
- Connect the DC (negative) supply wire from the battery to the black wire of the refrigerator.

### Select Wire Size

### WARNING

Assuming vehicle battery supplies a minimum voltage of 12 VDC, select the AWG wire size so the voltage drop from the vehicle battery or power converter is no more than 0.3 VDC.

### Recommended Wire Size

N8DCX / N10DCX Cable Size Acceptance			
	AWG	Cable Length (Feet Max)	Cable Strand Count
Same length Positive / Negative Cables	10	0 - 15	>= 19
	8	0 - 20	>= 19
	8	0 - 25	>= 133
	6	0 - 40	>= 133
	6	0 - 45	>= 266

# DIAGNOSTICS

## Diagnostic Flowchart

Diagnosing problems begins by starting with the basics. In many cases, the problem can be solved by verifying the unit is operating in acceptable conditions. Before performing detailed diagnostics make sure:

- The refrigerator is turned ON.
- The door is closed and sealing correctly.
- The refrigerator is correctly installed and the vents are not blocked.
- The vehicle fuse or circuit breaker is intact.

### NOTICE

There may be more than one (1) over-current device in the refrigerator supply circuit. Be sure to check both the RV and refrigerator.

- The ambient temperature is not unusually high (more than 110° F. / 43° C.).
- The air circulation inside the refrigerator is not decreased by foods or by shelves that are covered with plastic, paper, etc.
- The freezer is defrosted.
- The refrigerator is operating in the DAY mode (testing should not be done in the NIGHT mode).

Then do the following procedure.

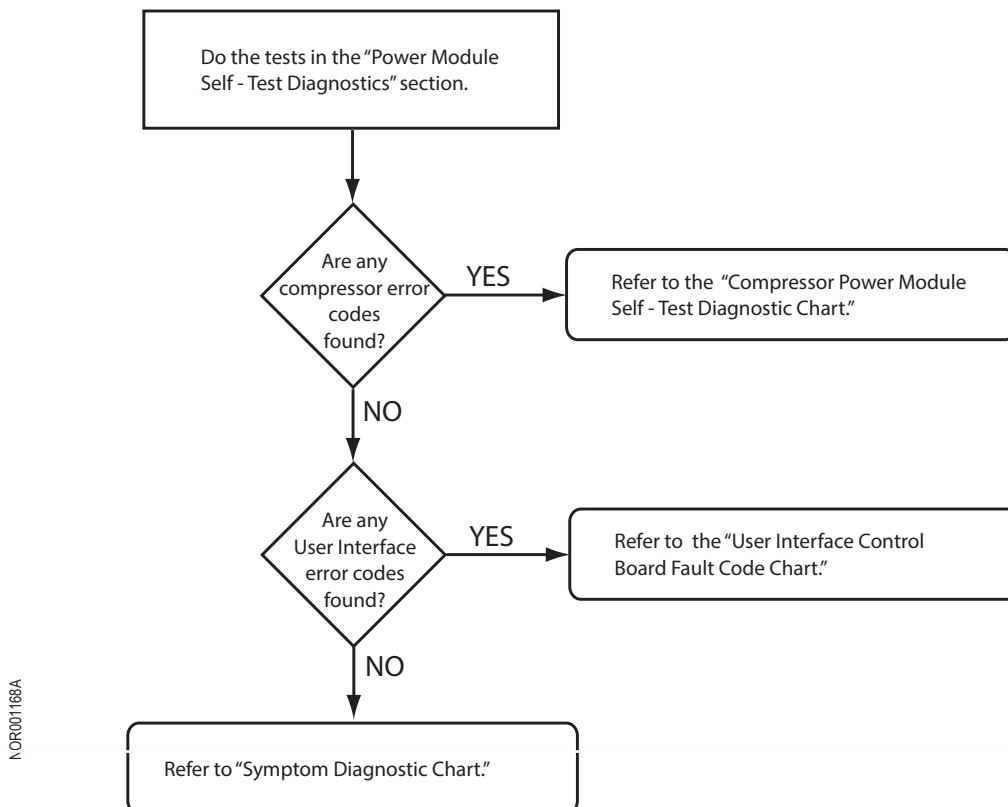

## Power Module Self-Test Diagnostics

The unit's compressor power module is equipped with a "Self-Test Diagnostic" function which can be read using light emitting diode (LED) and terminal connectors.

### Conducting the LED Evaluation

Follow the steps below. If an error code is activated in the compressor power module (Fig. 4.3, G) and the LED (Fig. 4.1, A) is connected, it will flash a number of times. The number of flashes will depend on what error was recorded. Each flash will last 1/4 second and after the code is flashed there will be a delay, then the code will repeat.

Write down all error codes; then refer to the "Compressor Power Module Self-Test Diagnostic Chart" in this section.

LED References for Figs. 4.1 - 4.6	
A	10 mA LED With Wire Leads
A1	Black LED Wire (with connector attached)
A2	Red LED Wire (with connector attached)
B	1/4 Inch Push-On Female Connector (2x)
C	1/4 Inch Adapter With One (1) Female and Two (2) Male Connections
D	12 VDC Input Wire
E	Positive (+) Terminal "+" of Compressor Power Module
F	Terminal "D" of Compressor Power Module
G	Compressor Power Module

### Prepare to Connect the LED

You will need the following to conduct self-diagnostics:

- One (1) 10 mA LED with wire leads (See Fig. 4.1, A).
- Two (2) 1/4 inch push-on female connectors (See Fig. 4.1, B).
- One (1) 1/4 inch adapter with one (1) female to two (2) male connections. (See Fig. 4.1, C)

### NOTICE

Do not leave jumpers in place for normal operation.

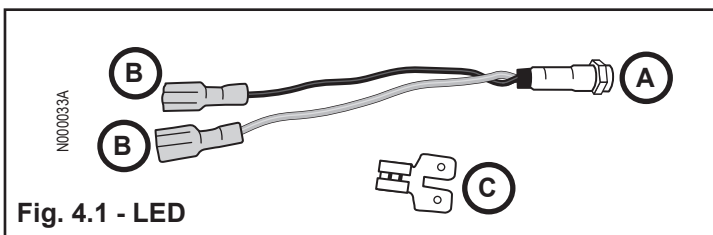

Fig. 4.1 - LED

### Connect the LED

Refer to Figs. 4.2- through 4.6

#### Step 1. Attach Female Connectors.

- Attach a female connector to each LED wire lead.

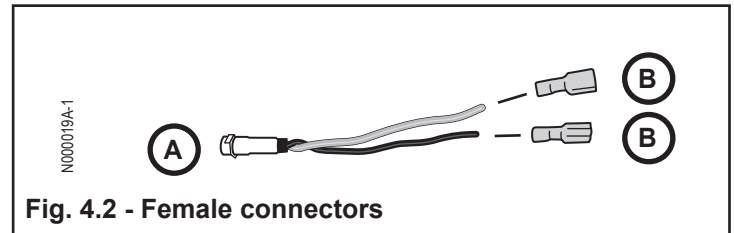

Fig. 4.2 - Female connectors

#### Step 2. Disconnect 12 VDC

- Disconnect the 12 VDC input wire from the positive terminal of the compressor power module.

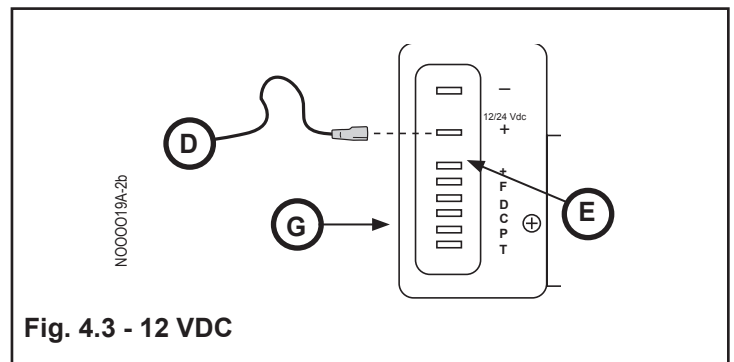

Fig. 4.3 - 12 VDC

#### Step 3. Connect Adapter

- Connect the adapter to the positive terminal of the compressor power module.

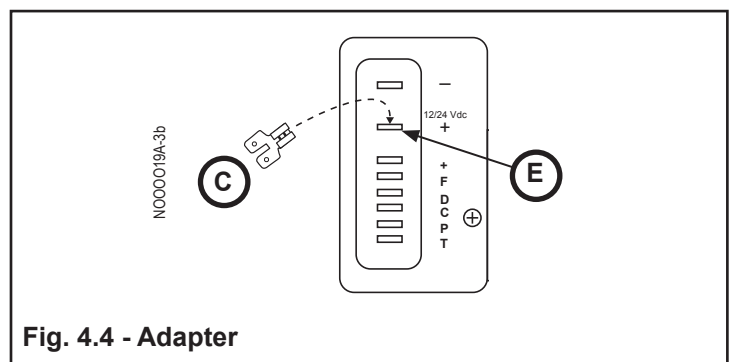
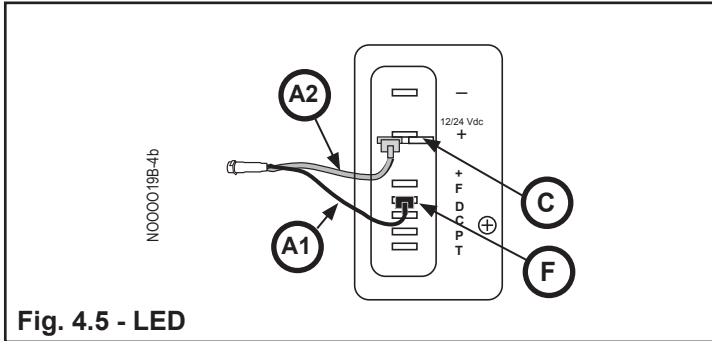

Fig. 4.4 - Adapter

**Step 4. Connect LED**

- Connect the red LED wire (A2) to one side of the adapter.
- Connect the black LED wire (A1) to terminal "D" of the compressor power module.



**Fig. 4.5 - LED**

**Step 5. Connect 12VDC**

- Connect the 12 VDC input wire to the other side of the adapter.

**NOTICE**

Do NOT leave jumpers in place for normal operation.

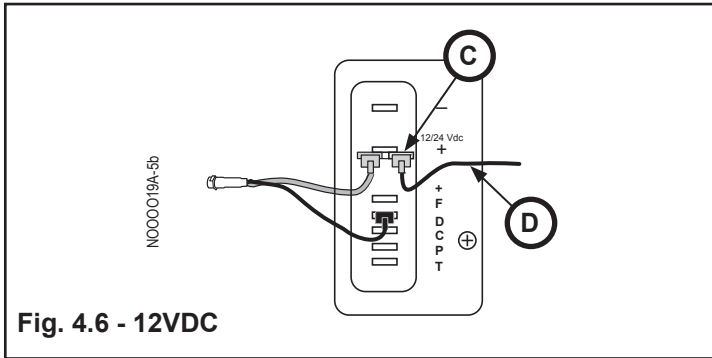

**Fig. 4.6 - 12VDC**

**Diagnostic Charts**

**Compressor Power Module Self-Test Diagnostic Chart**

Flashes	Description	Action
1	<b>Compressor Power Module Battery Protection Cut-Out.</b> The voltage is outside the compressor cut-out setting of 9.8 - 17.0 VDC.	Perform Test A.
2	<b>Fan Over Current Cut-Out.</b> The load is more than 1.0 amp sensed on terminal "F-".	Perform Test B.
3	<b>Compressor Motor Start Error.</b> The rotor is blocked or the differential pressure in the refrigeration system is too high (>5 bar).	Perform Test C.
4	<b>Minimum Compressor Motor Speed Error.</b> The motor can not maintain minimum speed (1850 rpm).	Perform Test D.
5	<b>Thermal Cut-Out of Compressor Power Module.</b> The compressor power module is running too hot (>203°F)	Perform Test E.
6	<b>Compressor Power Module Hardware Failure.</b> A failure is detected in the compressor power module.	Perform Test K.

**Symptom Diagnostic Chart**

Problem	Possible Cause	Action
Not cooling. Compressor not turning on.	- Faulty thermistor. - No power to compressor power module. - Faulty wire from compressor power module to compressor motor. - Faulty compressor power module. - Faulty compressor motor.	Perform Test F.
Refrigerator gets too cold.	- Bad capillary tube position. - Faulty thermistor or thermistor wiring. - Faulty compressor power module. - Faulty user interface board. - Faulty connections on user interface board. - Faulty diverted valve or diverter valve wiring.	Perform Test G.
Refrigerator builds frost inside.	- Door not fully closed. - Damaged door gasket. - Temperature setting is too cold. - Higher ambient humidity. - Door opened too often, too long.	Perform Test H.
Compressor runs, but does not cool properly.	- High ambient temperature. - Blocked air ventilation. - Frost build up. - Condenser coil restricted. - Faulty condenser fan. - Faulty cooling unit. - Faulty user interface control board. - Faulty wiring. - Faulty compressor motor.	Perform Test I.
Will not run on DC power.	- Blown fuse in DC circuit. - Undersized wiring to refrigerator. See "Recommended Wire Size" chart for required wire size. - Partially discharged battery, Voltage below 11.9 VDC at compressor power module. - High resistance (voltage drop) in DC supply circuit.	Perform Test J.
Voltage within range but refrigerator powers off.	- Input voltage may register within specification, but cut-out because of inadequate load carrying capability.	Perform Test K.

**User Interface Control Board Fault Code Chart**

Fault Code	Fault Code Meaning	Action to Take
E1	The thermistor in the fresh food compartment is not cycling properly.	Refer to "Fault Code - "E1"" on page 29.
E2	The thermistor in the freezer compartment is not cycling properly.	Refer to "Fault Code - "E2"" on page 31.
E3	The voltage is outside the cut out setting.	Refer to "Fault Code - "E3"" on page 33.
E4	The fresh food compartment door has been open for more than two (2) minutes.	Refer to "Fault Code - "E4"" on page 34.

# Test A - Compressor Power Module Battery Protection Cut-Out

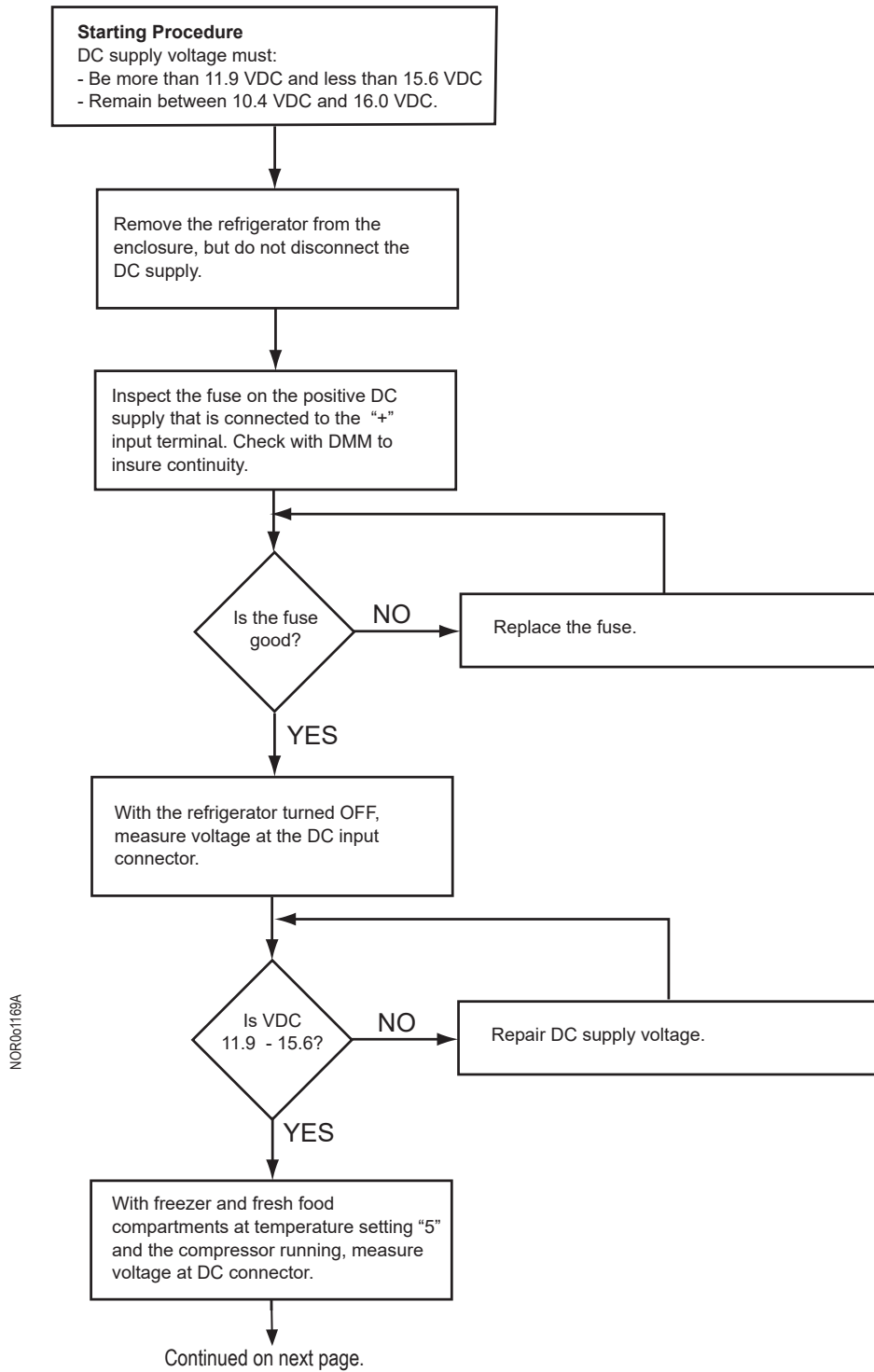

Continued from previous page.

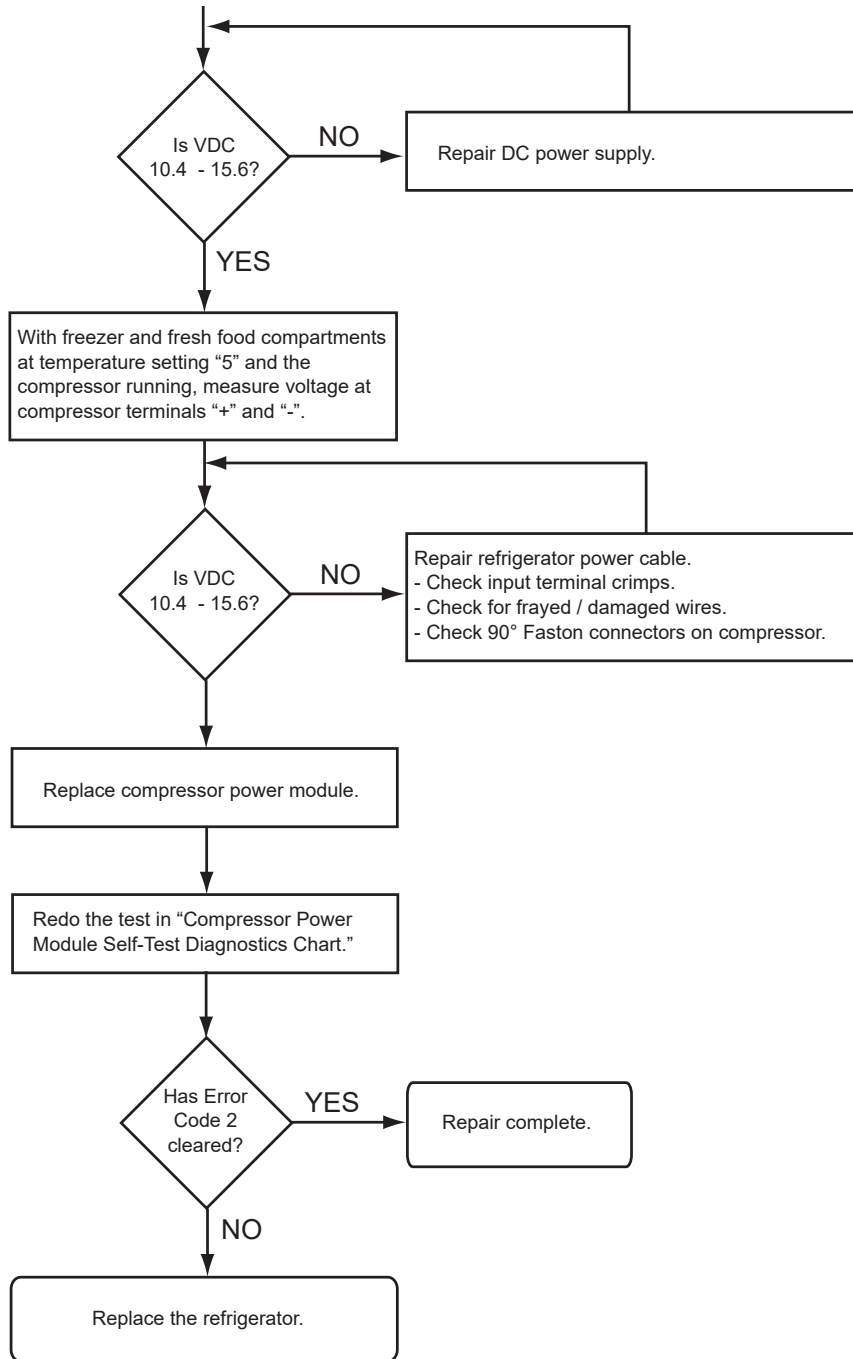

NOR001169A

## Test B - Fan Over Current Cut-Out

### NOTICE

The compressor power module has a built in over-current protection, however this refrigerator does not use the compressor power module for fan operation management. If this error occurs, there is either a wiring problem or a compressor power module problem.

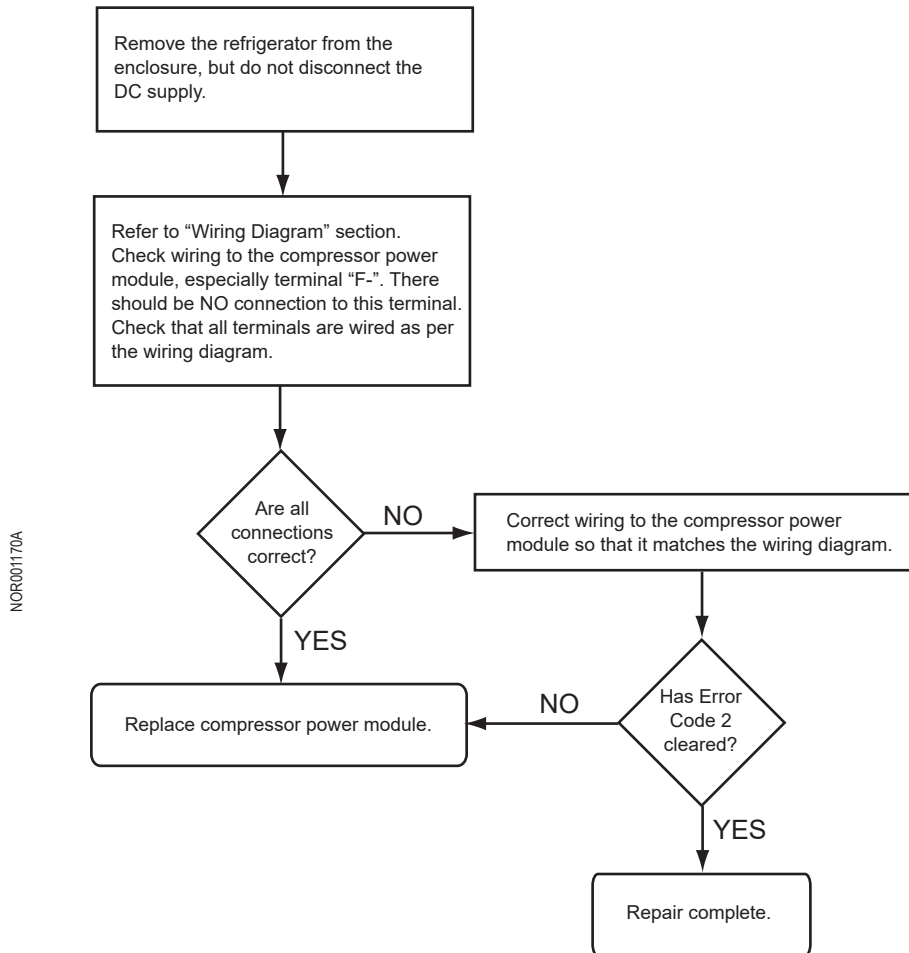

## Test C Compressor Motor Start Error

---

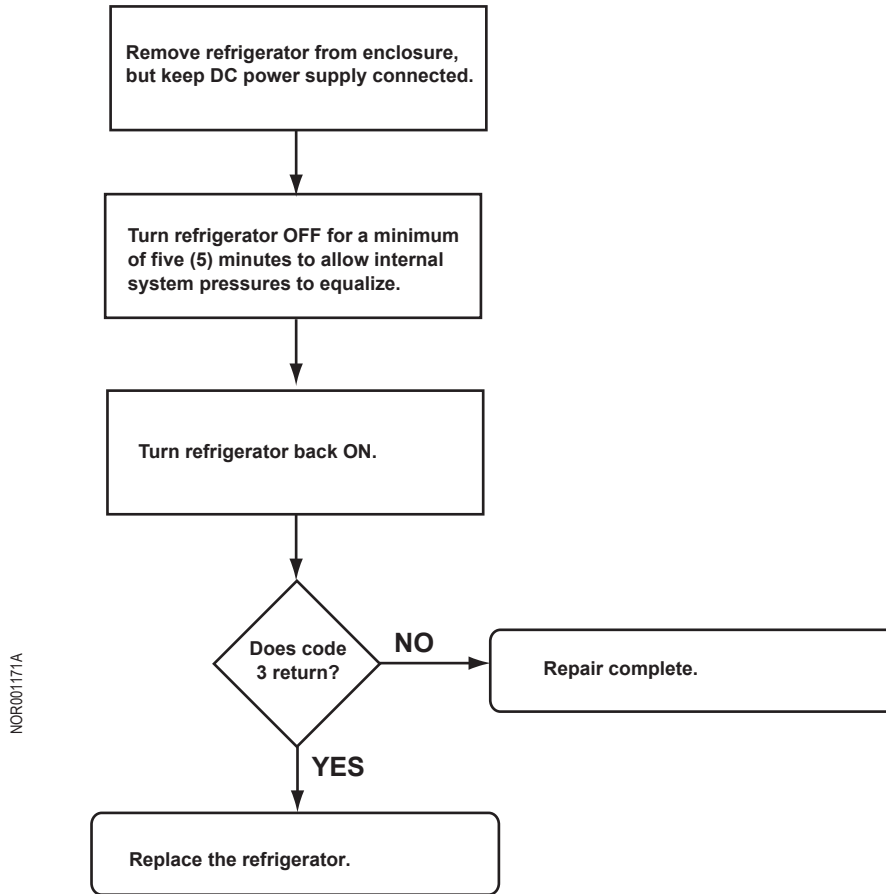

## Test D - Minimum Compressor Motor Speed

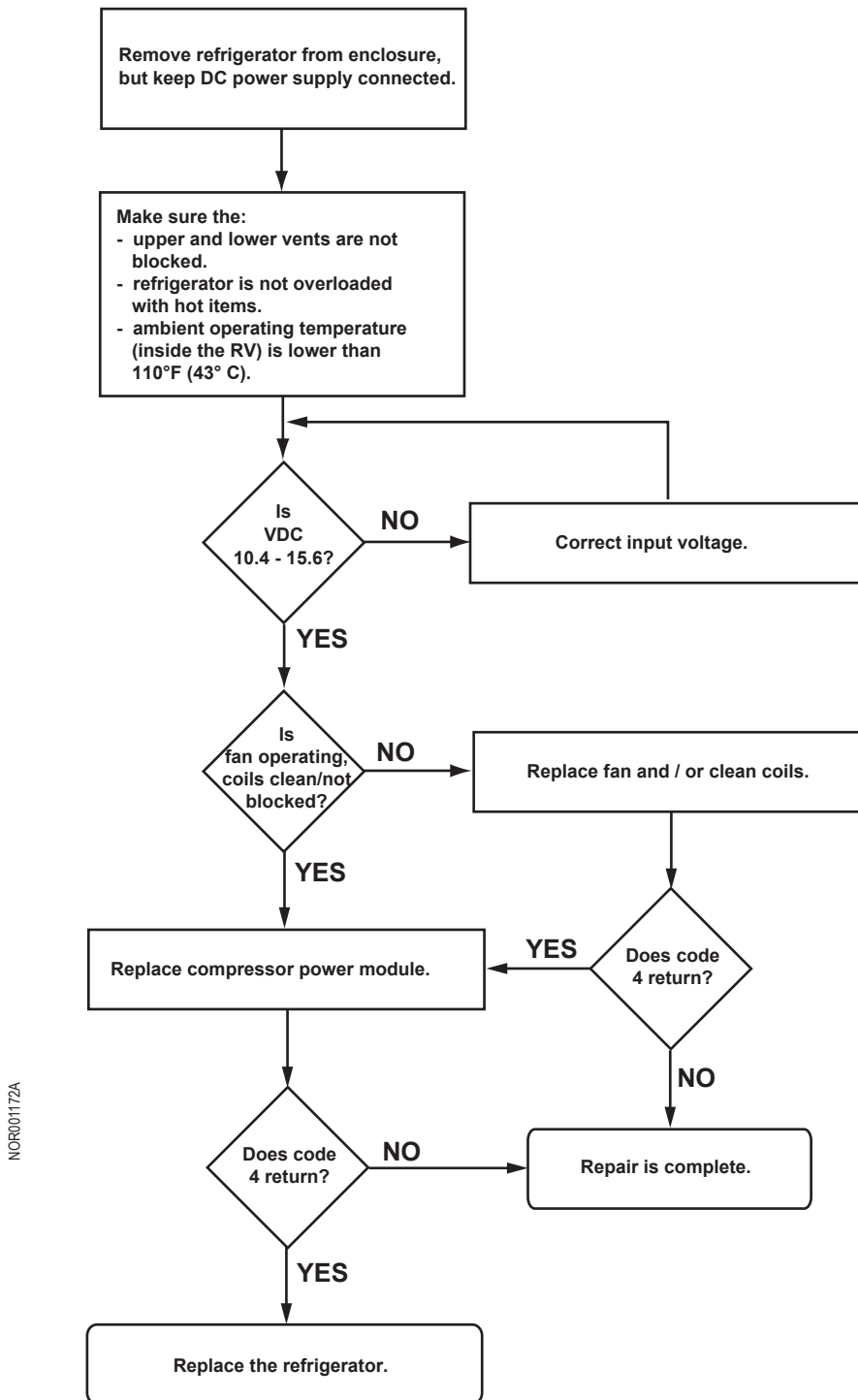

## Test E - Compressor Power Module Thermal Cut-Out

### NOTICE

The compressor power module has a built in thermal protection which stops the compressor operation if the compressor power module circuit board temperature is higher than 203° F (95° C). The refrigerator will not restart until the compressor power module circuit board temperature is lower than 165° F (74° C).

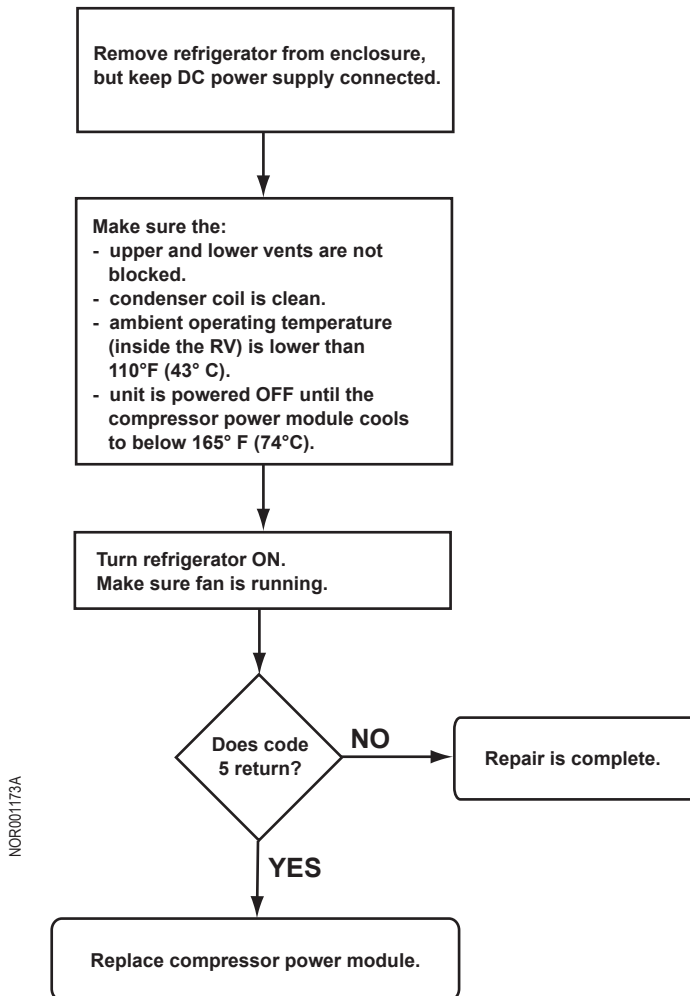

# Test F - Not Cooling, Compressor Not Turning ON

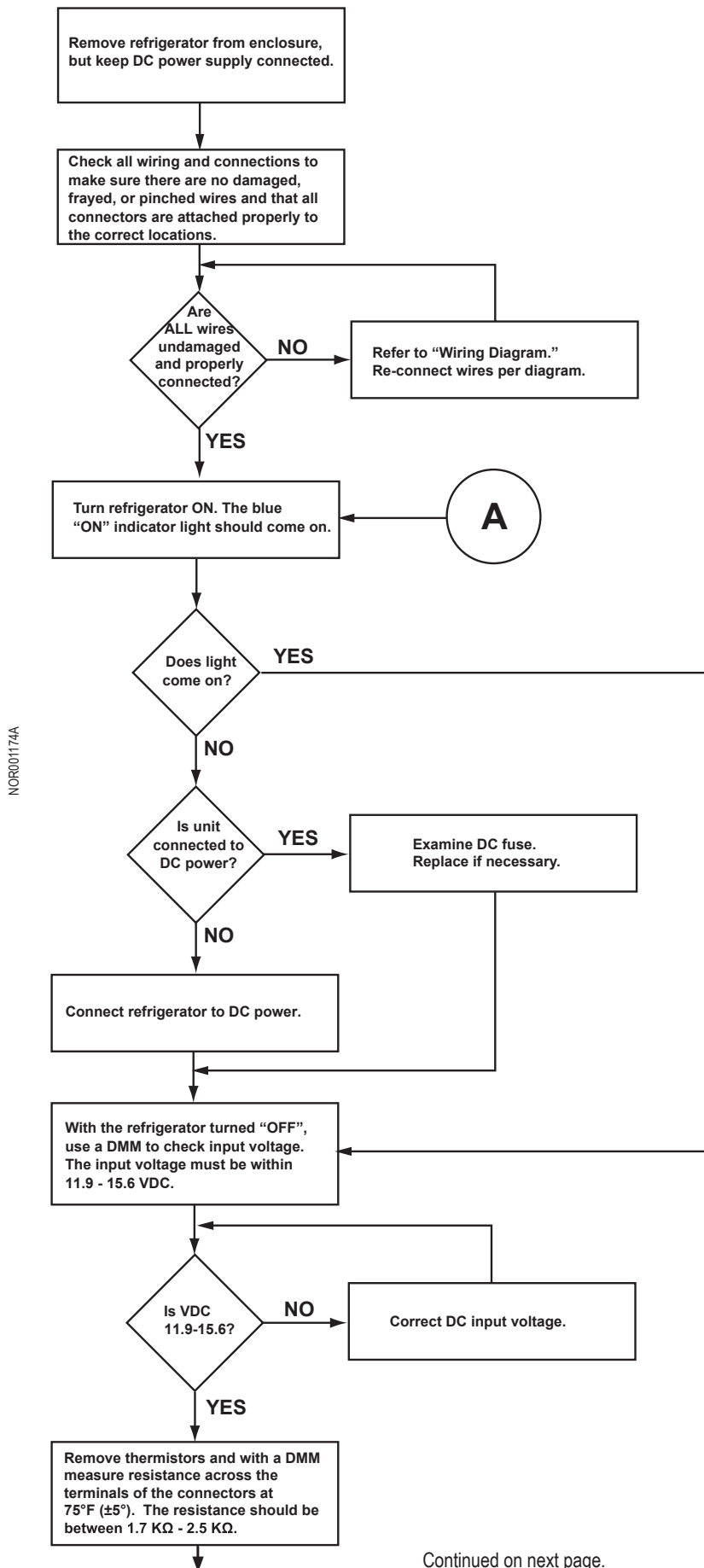

Continued on next page.

Continued from previous page.

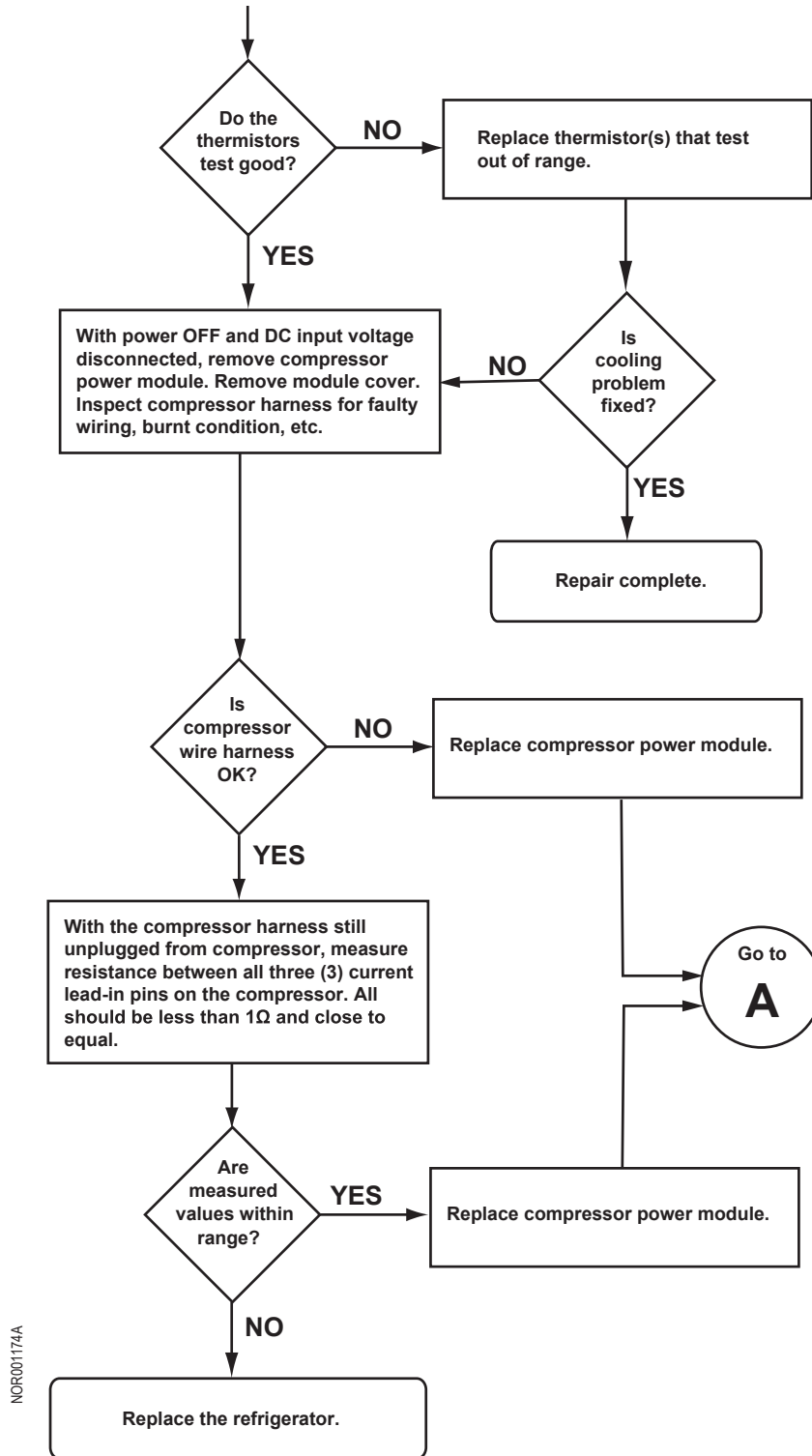

NOR00174A

# Test G - Refrigerator Gets Too Cold

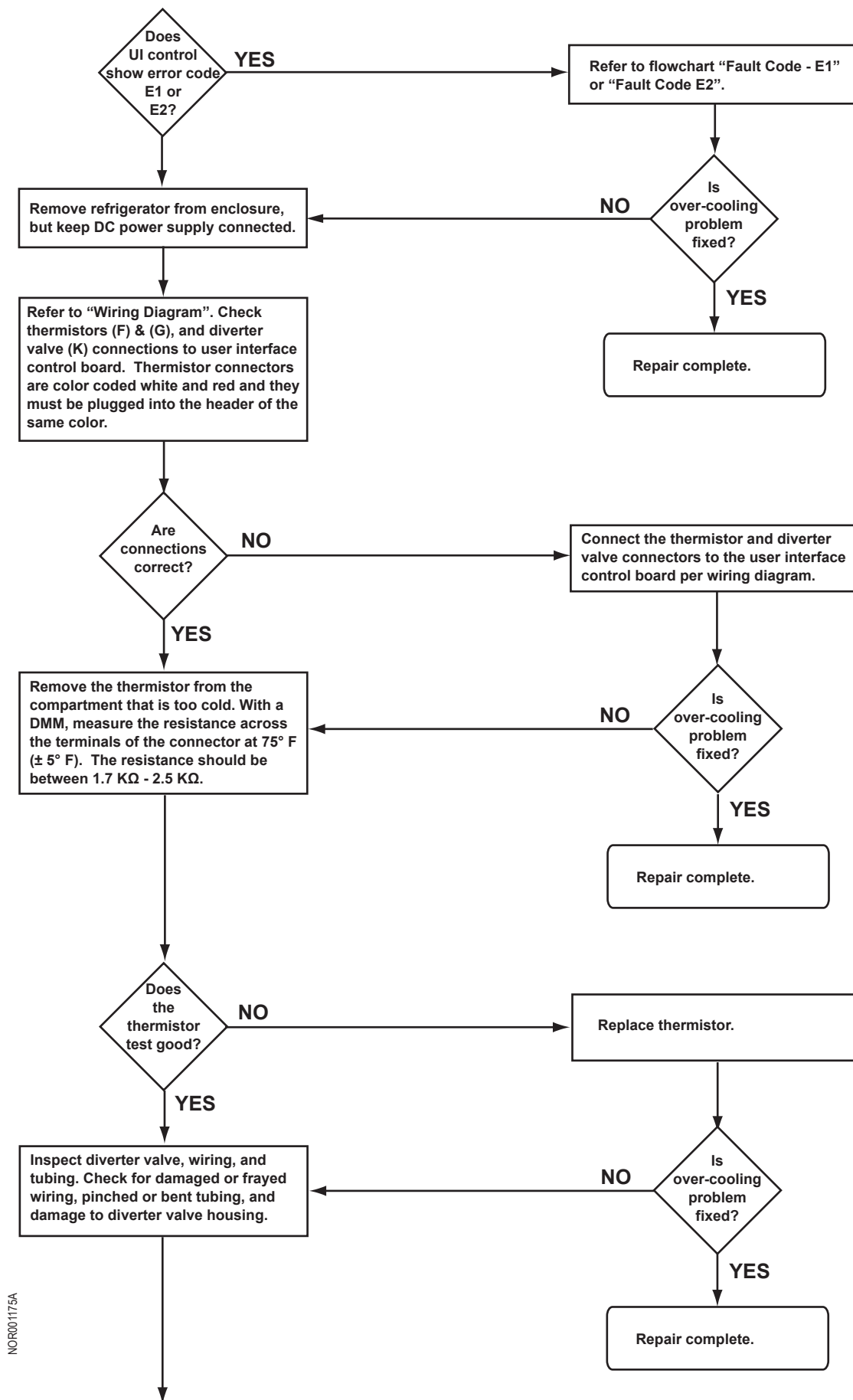

NOR001175A

Continued on next page.

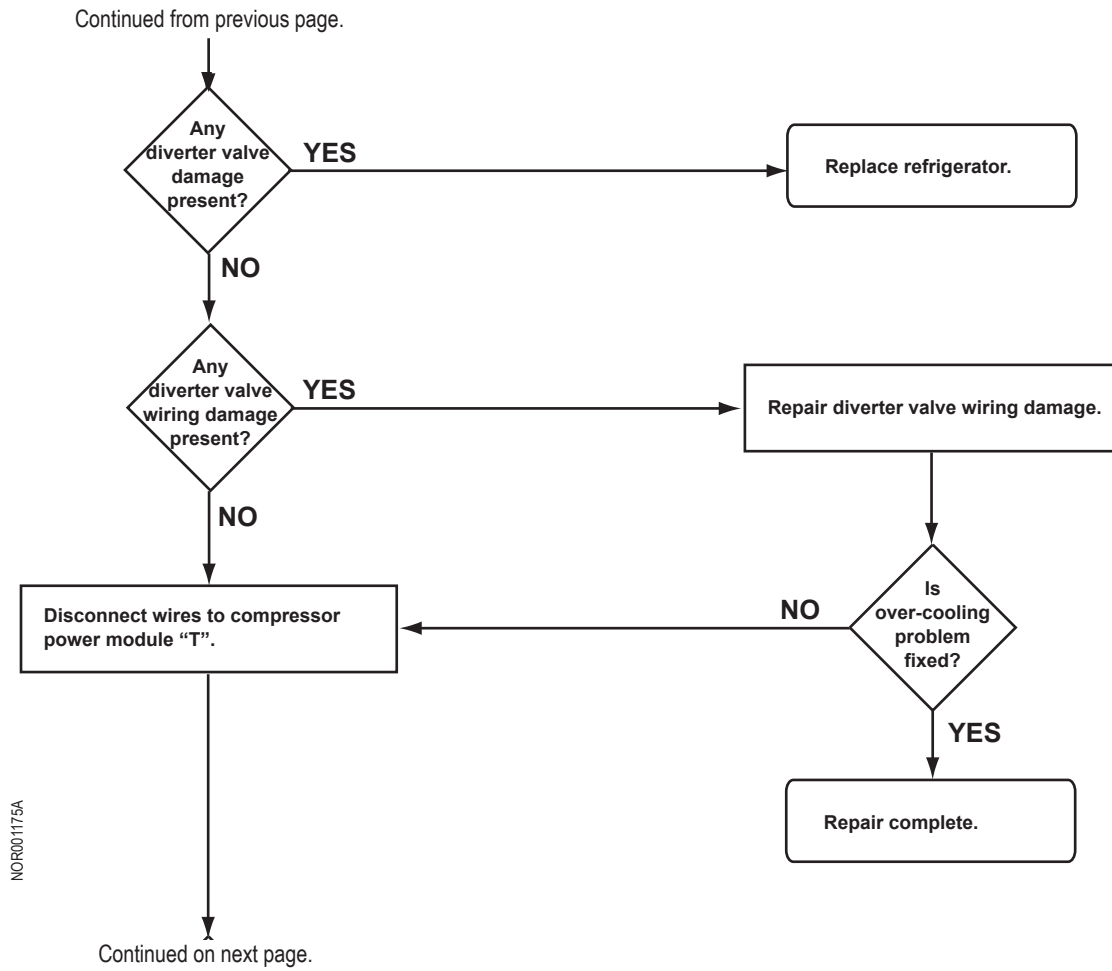

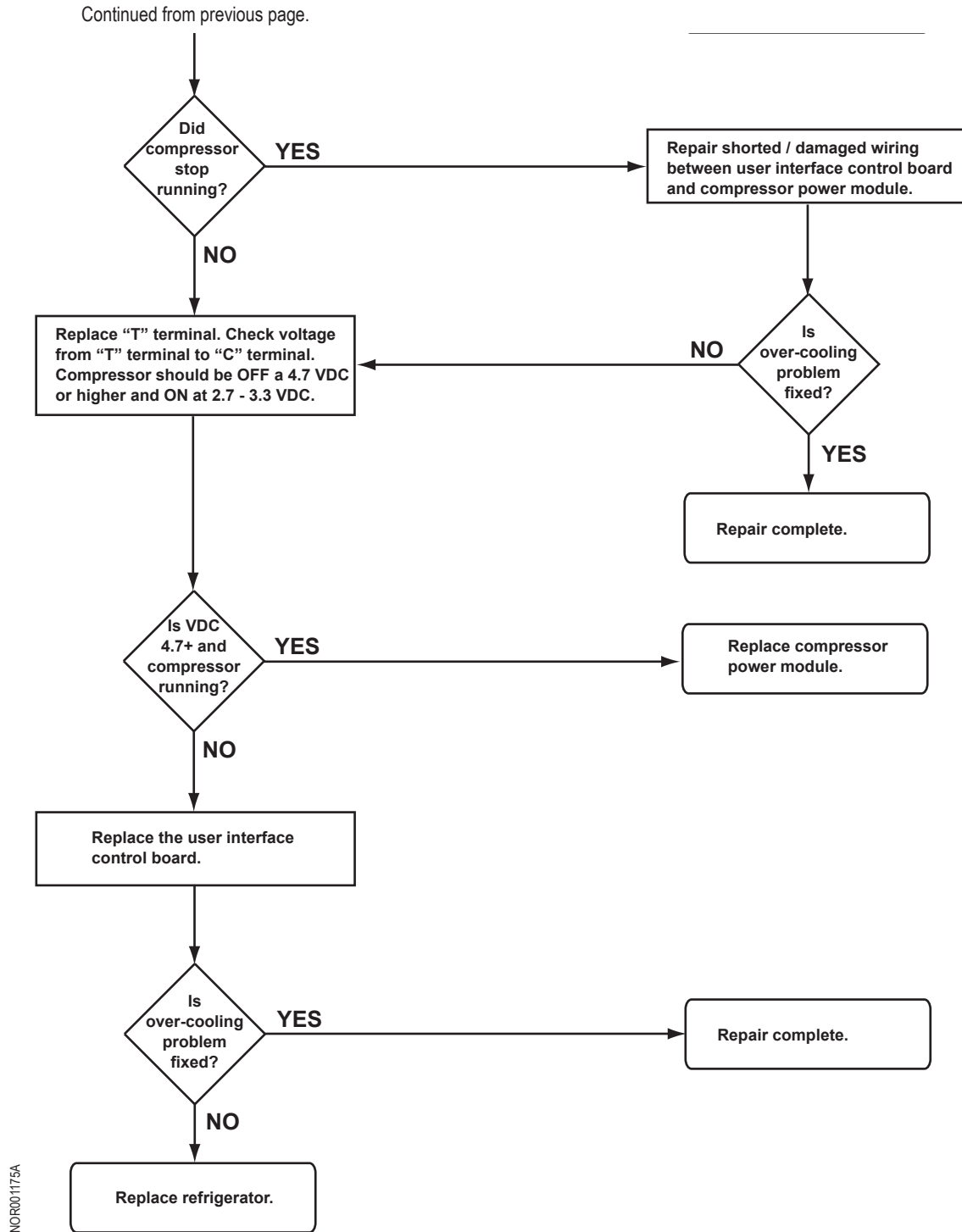

## Test H - Refrigerator Builds Frost Inside

### NOTICE

These models are not frost free units and must be defrosted at times. Three (3) common user-controlled conditions contribute to the problem:

1. Temperature selection at the coldest settings,
2. Door opened often and for long periods of time,
3. High humidity.

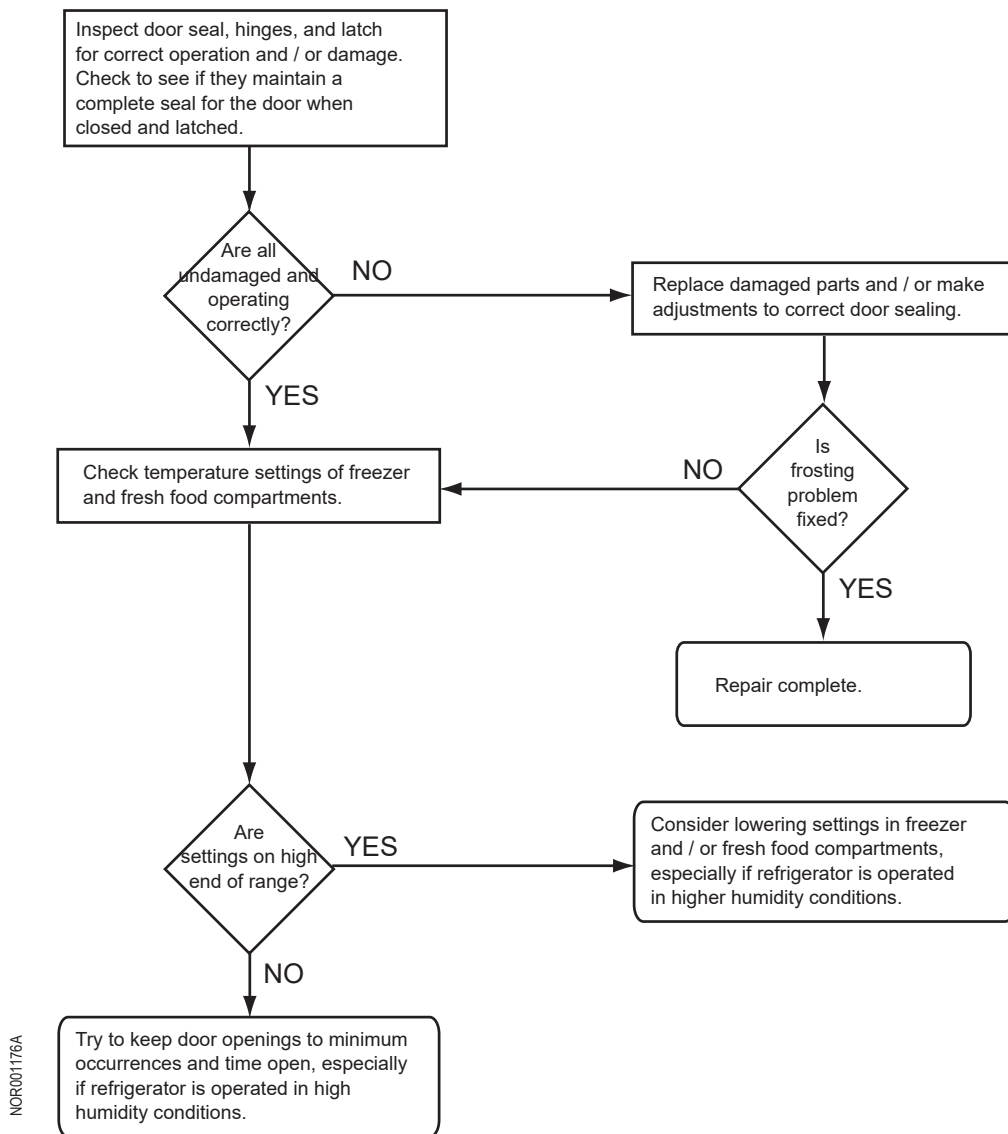

# Test I - Compressor Runs But Does Not Cool Properly

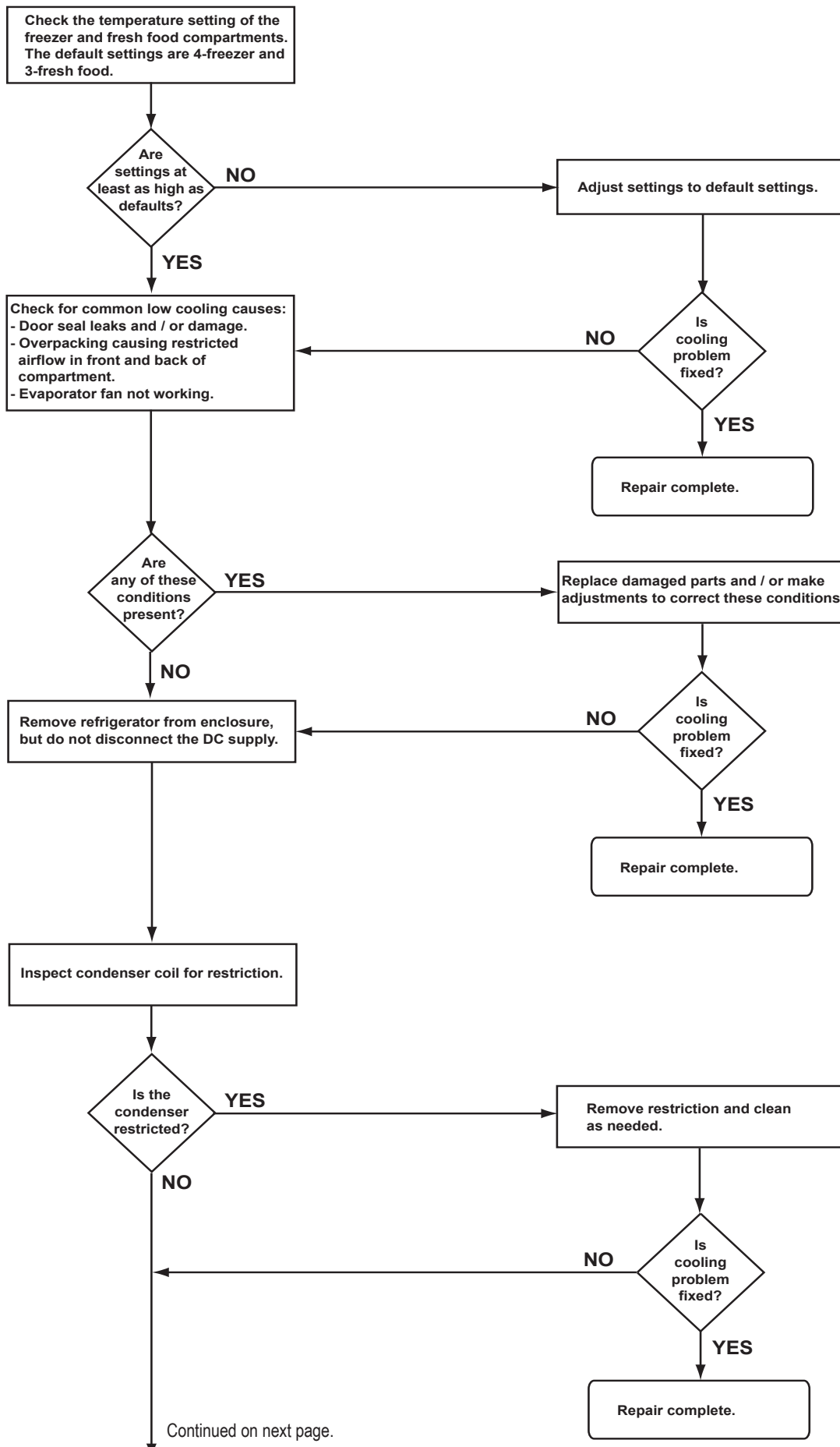

NOR001177A

Continued on next page.

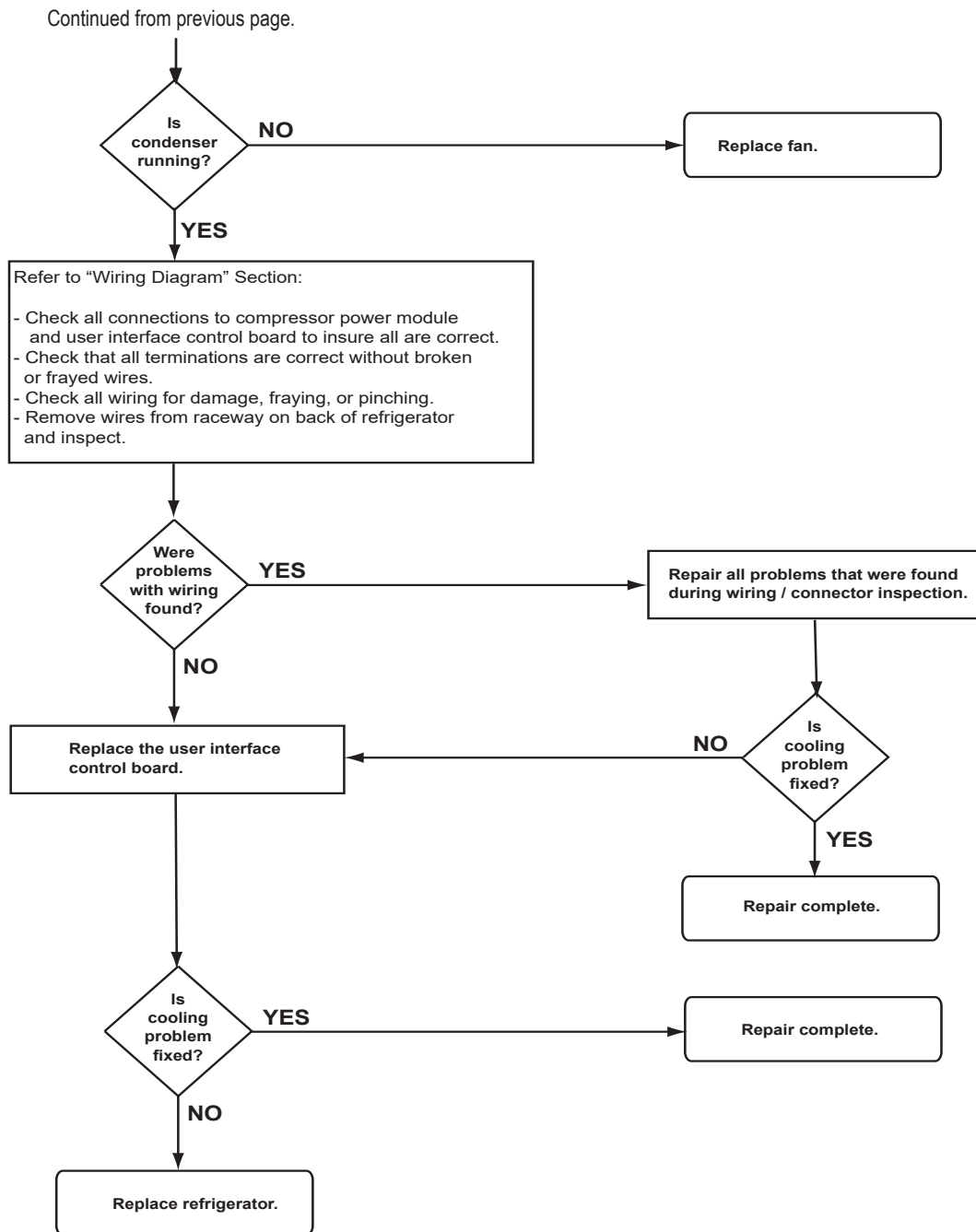

NOR001177A

# Test J - Will Not Run On DC Power

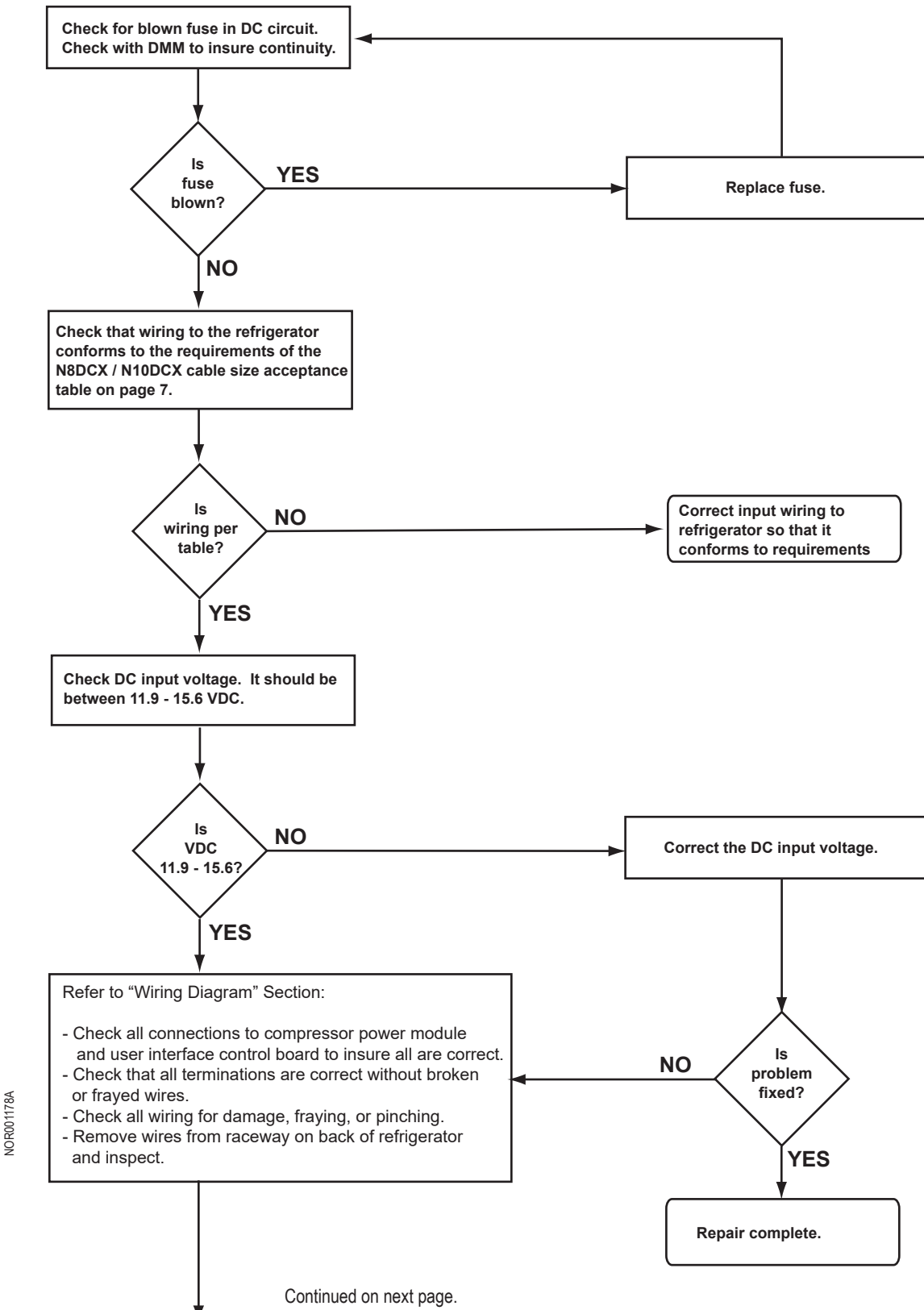

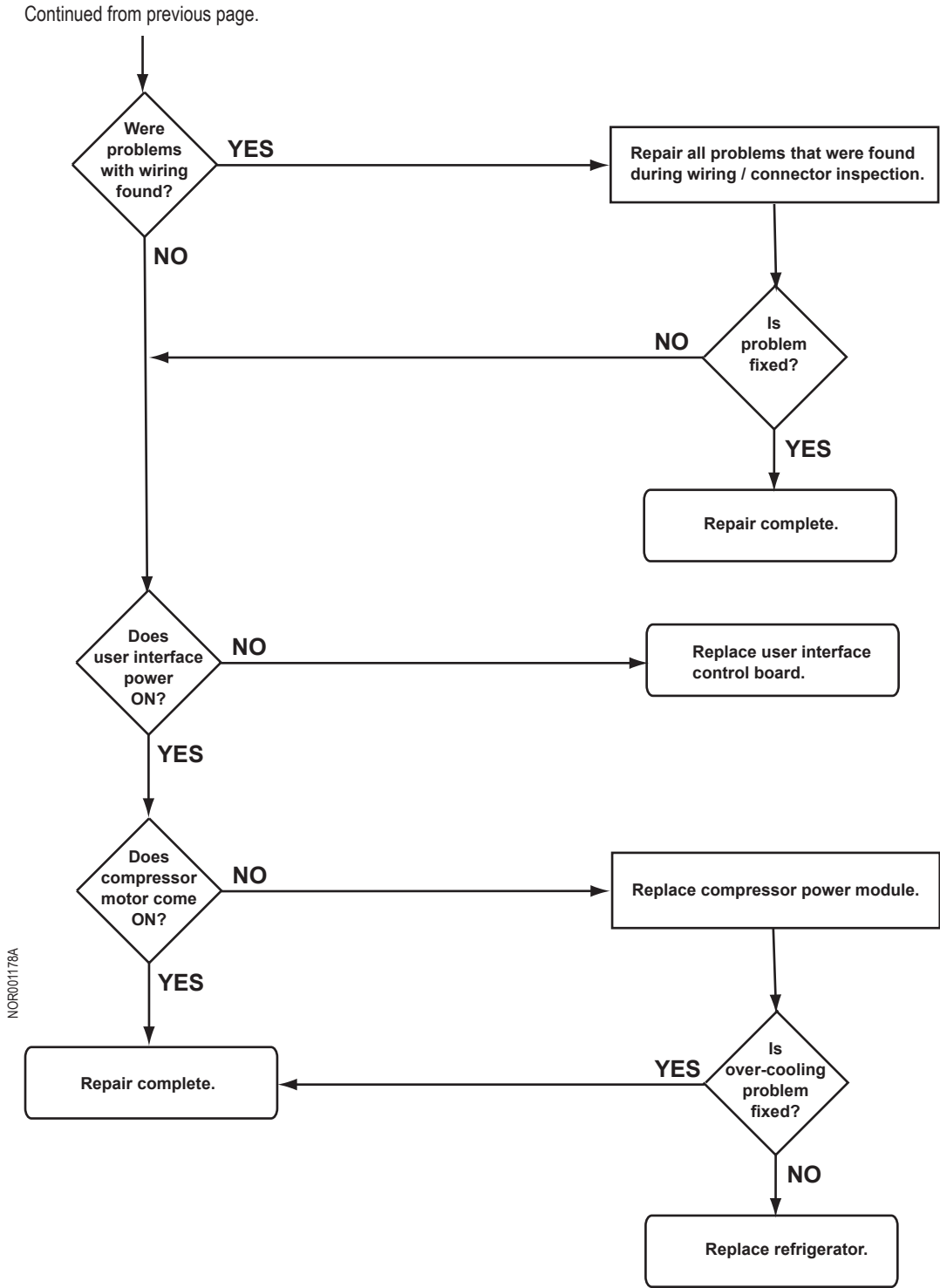

## Test K - Voltage Within Cut-Out Range But Refrigerator Powers OFF

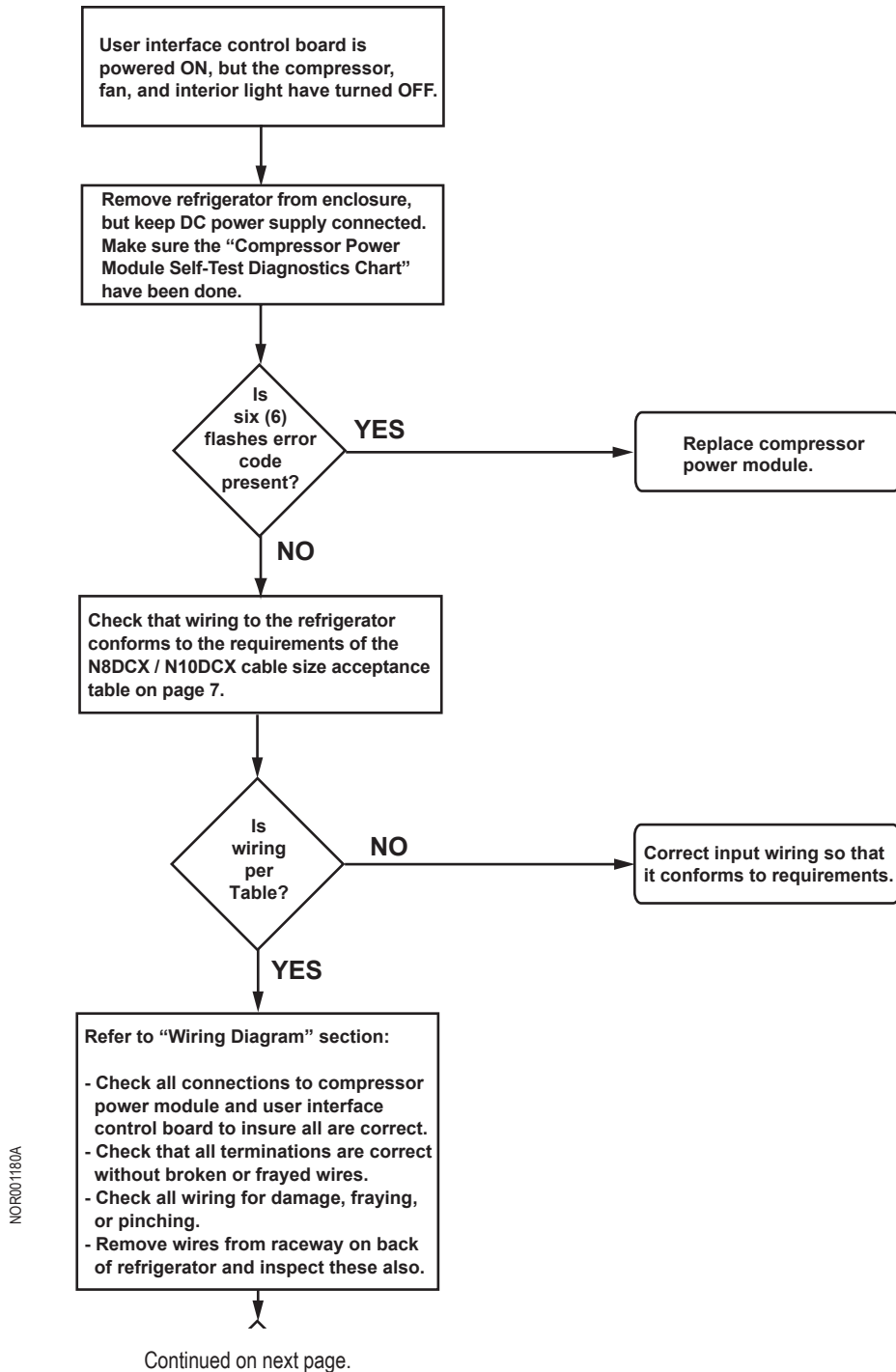

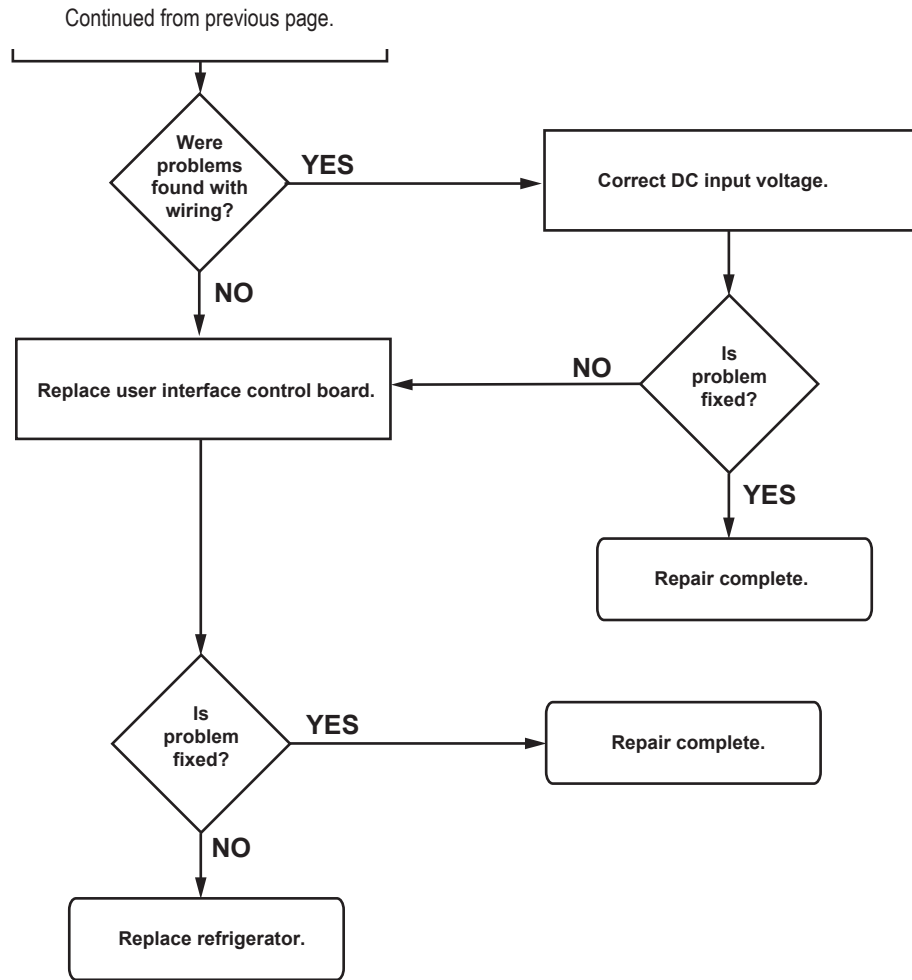

NOR00180A

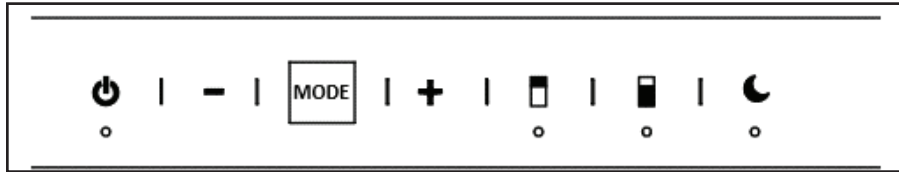
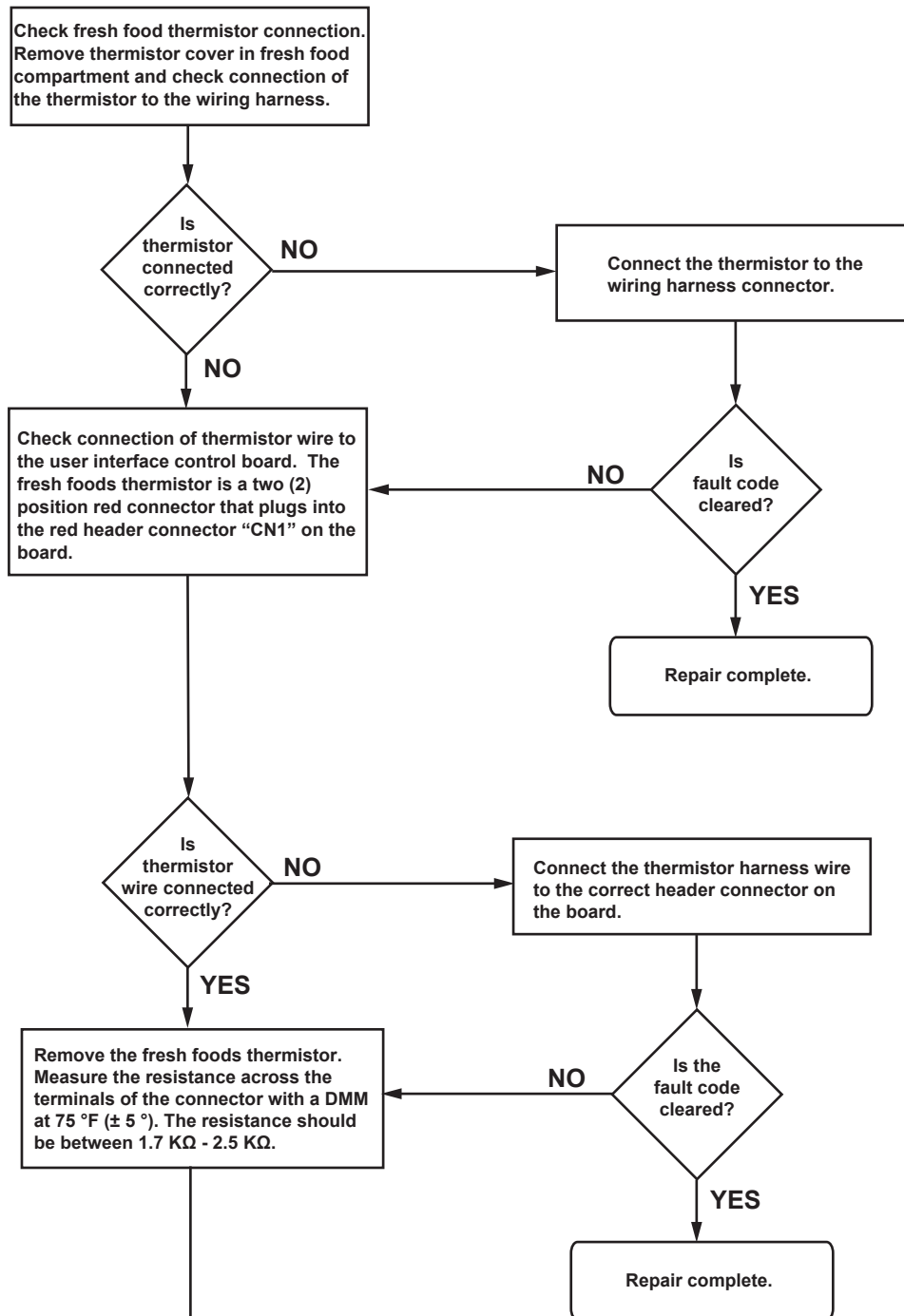

Fig. 5 - Mode button will display User Interface Control Board fault codes

Fault Code - "E1"



NOR001179A

Continued on next page.

Continued from previous page.

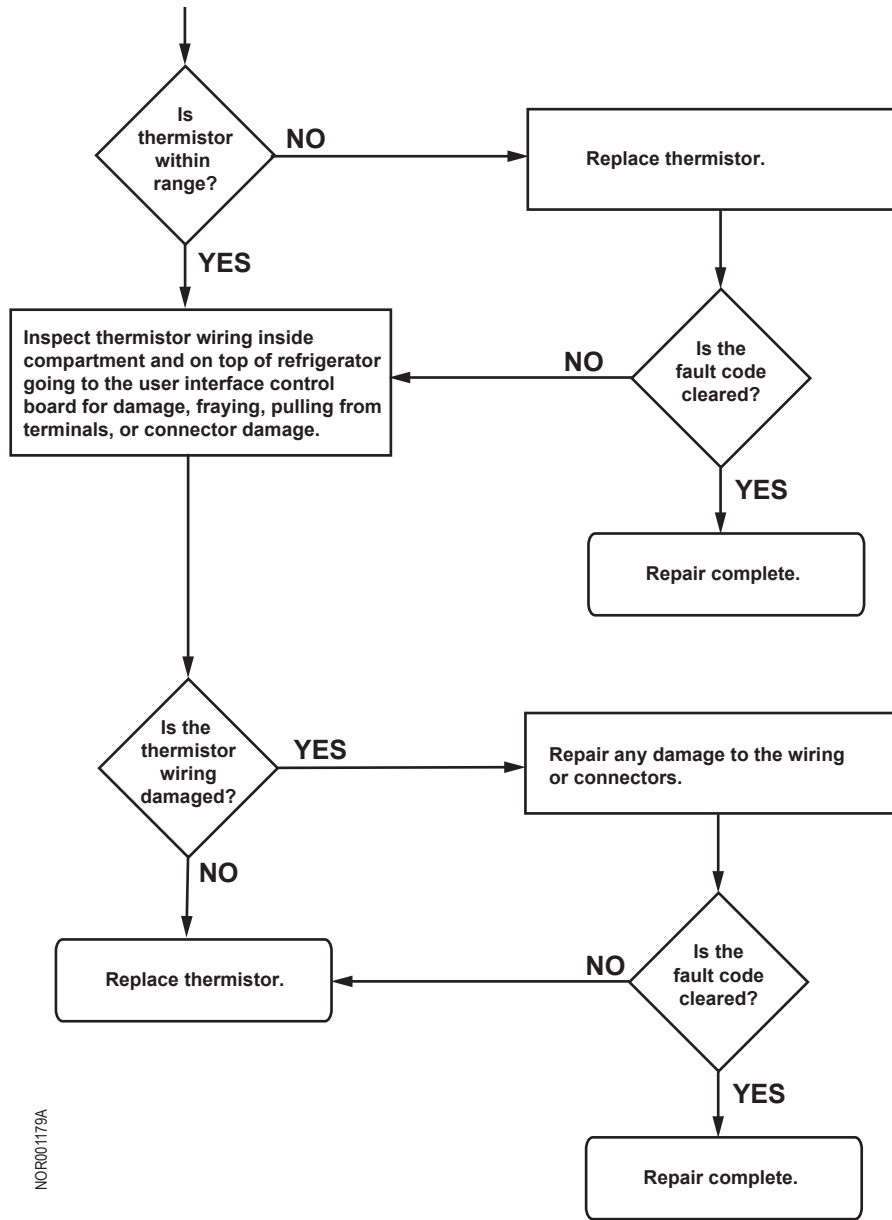

NOR001179A

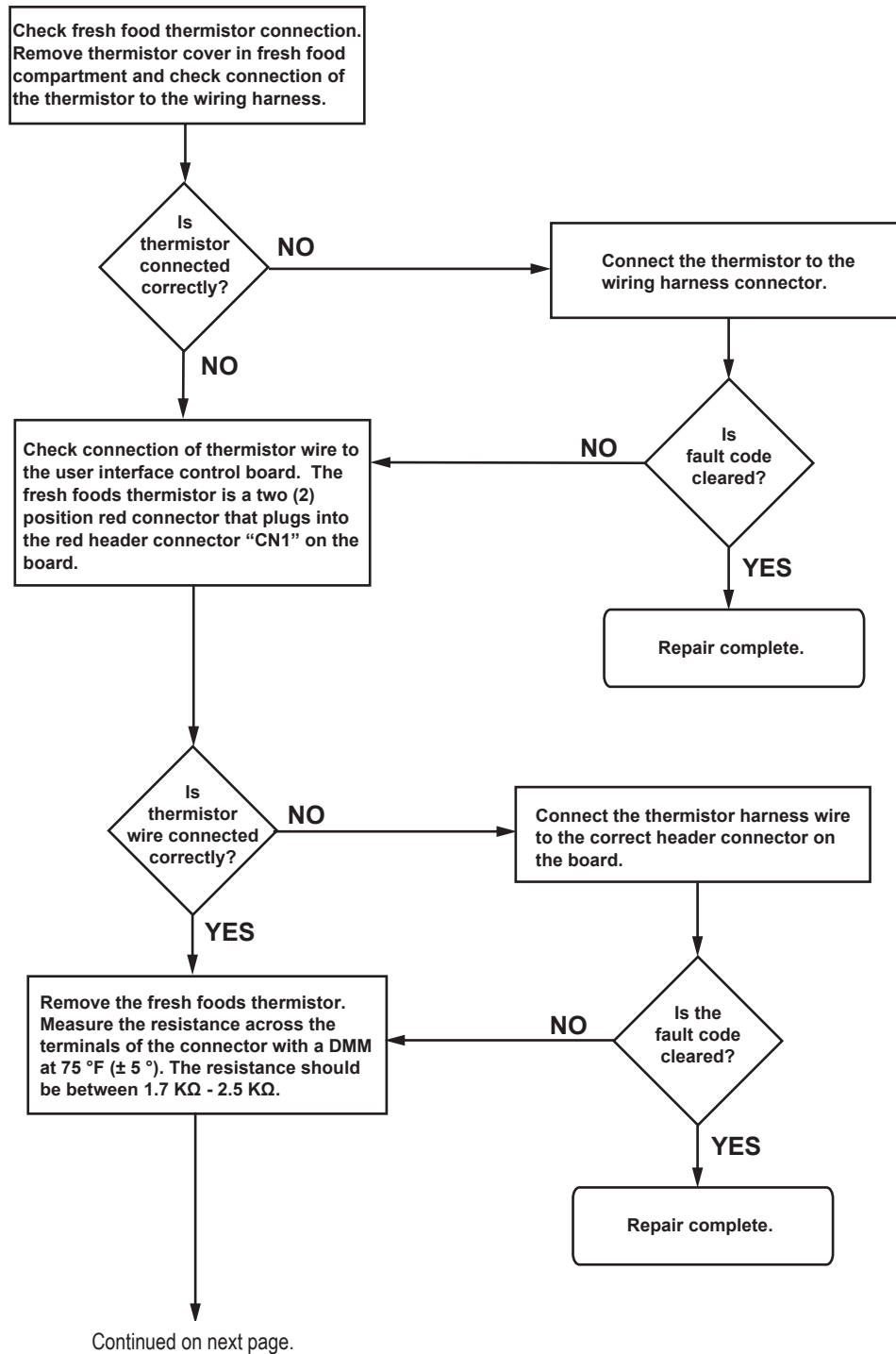

NOR001181A

Continued from previous page.

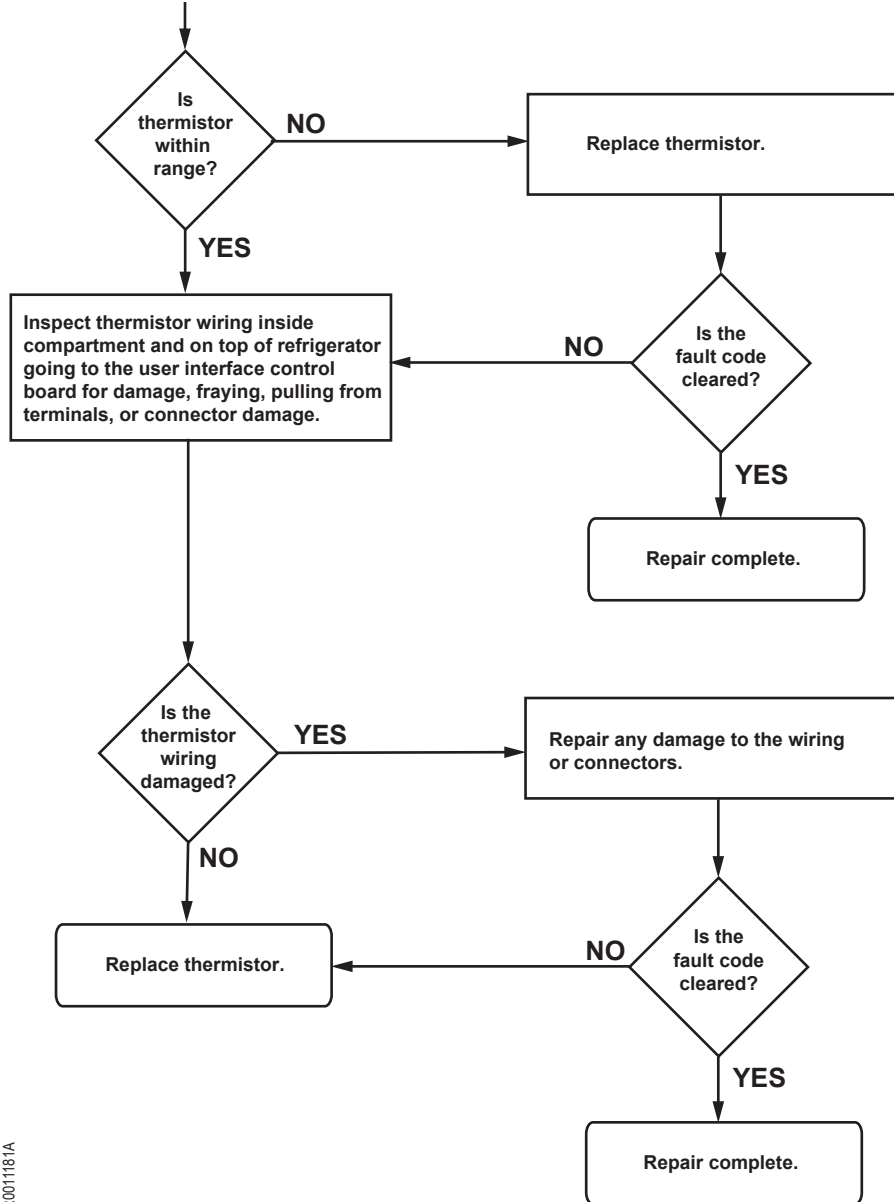

NOR001181A

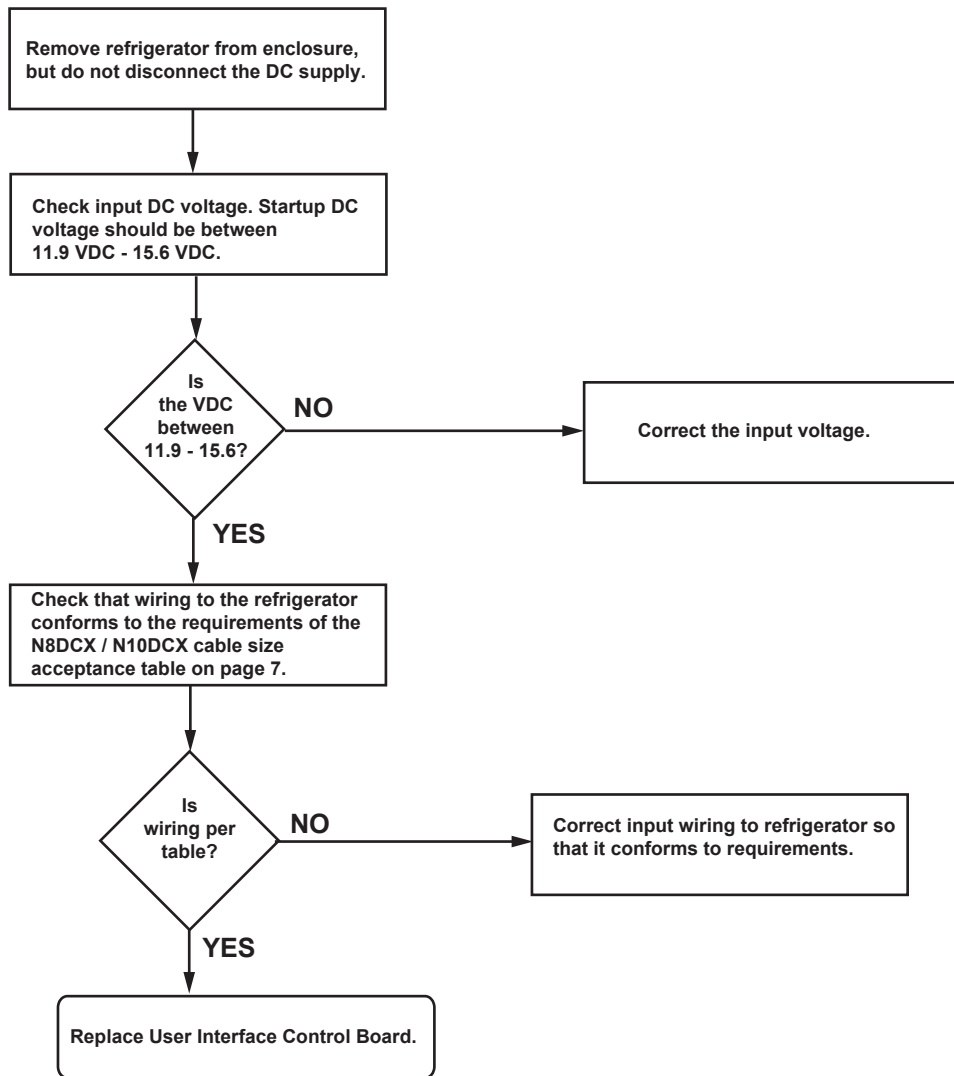

NOR001182A

## Fault Code - "E4"

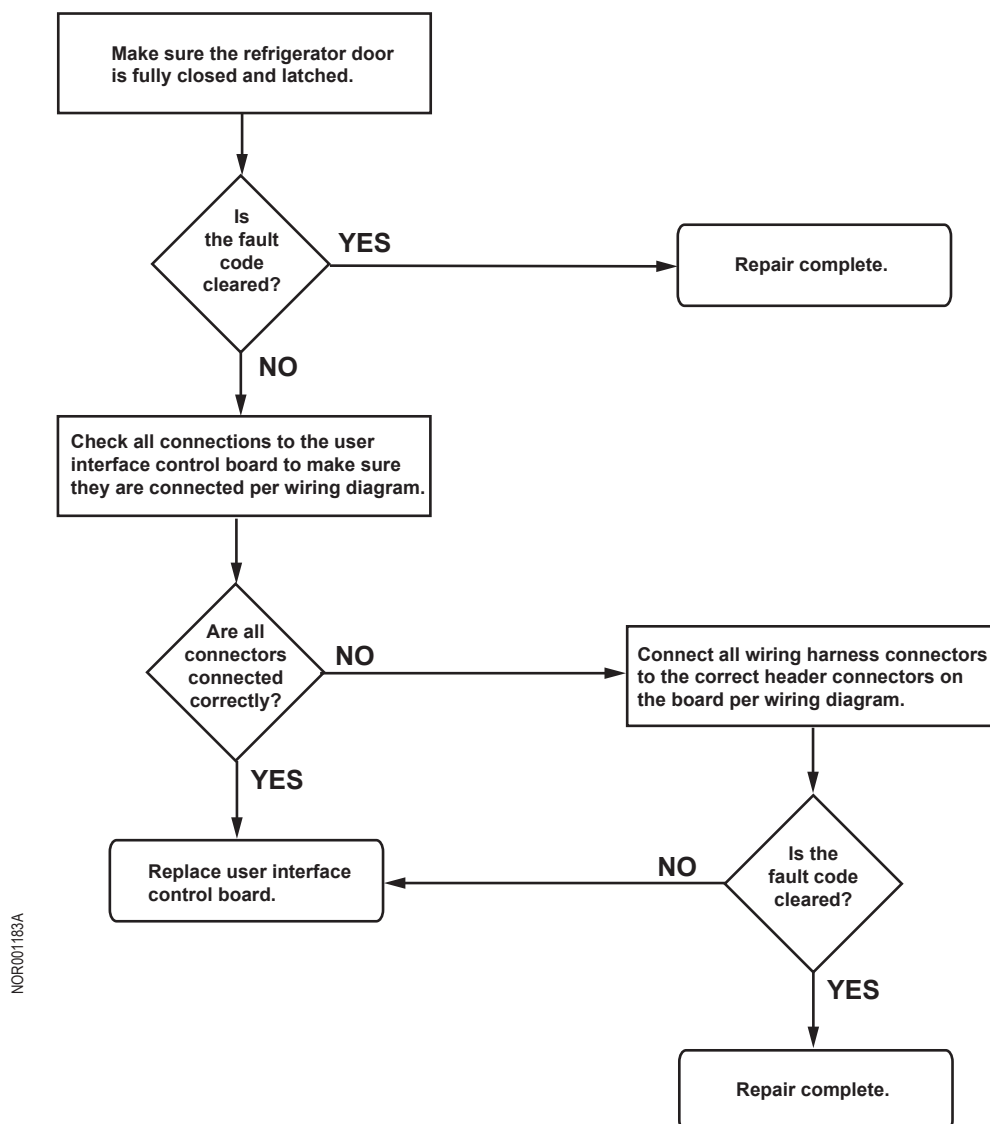



# REFRIGERATOR ENCLOSURE

---

## **Remove Refrigerator**

---

1. Disconnect all power supplies to the refrigerator.



Failure to disconnect the electrical sources can cause dangerous personal injury or death.

2. Remove the mounting screws from each mounting bracket. Pull the refrigerator forward.

## **Replace Refrigerator**

---

1. Push refrigerator fully into enclosure. Install screw into each mounting bracket.
2. Connect all power supplies to the refrigerator.